



Soldering station & Soldering spare parts

*Desoldering station
Static control equipments & Spare parts
Industrial tools*

Bakon®



■ Enterprise Introduction

Shenzhen Baiguang Electronic Technology Co., Ltd. was established in 1998. It is committed to the overall solution of electrostatic prevention and control, automated lean production, lead-free welding, industrial tools, purification and auxiliary equipment R&D, production and sales. The main brands are BAKON and SBK.



The company adheres to the business tenet of "Science and Technology-Based, Creates a World Brand", pursues the corporate philosophy of "Customer First, Pursuit of Excellence, High-tech National High-efficiency Tool Brand", and adheres to the quality policy of "Following standards, technological innovation, and continuous improvement". With its reliable quality, stable performance, unique appearance, and high-quality service, "white light products" stand in the electronics manufacturing industry and enjoy a worldwide reputation.

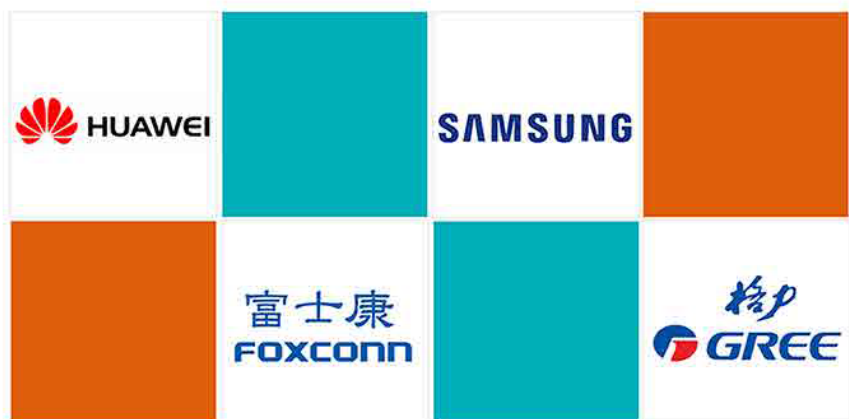

BK861

Smart hot air desoldering station

1. Use high-definition large LCD color screen display.
2. There are three working channels of CH1, CH2 and CH3, and the air volume and temperature of each channel can be set.
3. With password protection function and key lock function.
4. Real-time operation is convenient, with magnetic control switch control, the handle is placed on the handle frame and it will immediately enter sleep.
5. With automatic sleep function, parameters can be set in sleep state.
6. The sensor is closed loop, the microcomputer triggers the temperature control by zero crossing, the power is large, the temperature rises quickly, the temperature adjustment is convenient and accurate and stable, and it is not affected by the air volume.
7. The brush-less vortex fan is adopted, the air flow is adjustable, the range is large, and it can be adapted to various purposes.
8. The system is equipped with an automatic large air volume cooling function to extend the life of the heating element and protect the hot air handle.
9. It can interact with automation equipment online to realize information management.



Specification:

Model	BK861
Power/temperature range	1000W / 100°C- 500°C
Air volume range / max air volume	1~120/250L/min
Size / weight	L260xW190xH130+5mm/ about 5.1kg
Working environment	0~40°C / 32~104°F
Storage environment/storage temperature	-20~80°C / -4~176°F / 35%~ 60%
Screen display	HD LCD display
Fan type	Brushless vortex fan
Temperature calibration	Digital calibration temperature
Temperature control method	Microcomputer temperature control
I/O control port	Sleep signal/alarm output/temperature OK signal

Accessories:



Air gun seat



Nozzle

BK862

Intelligent dual-control hot air desoldering station

1. Use high-definition large LCD color screen display.
2. There are three working channels of CH1, CH2 and CH3, and the air volume and temperature of each channel can be set.
3. With password protection function and key lock function.
4. Real-time operation is convenient, with magnetic control switch control, the handle is placed on the handle frame and it will immediately enter sleep.
5. With automatic sleep function, parameters can be set in sleep state.
6. The sensor is closed loop, the microcomputer triggers the temperature control by zero crossing, the power is large, the temperature rises quickly, the temperature adjustment is convenient and accurate and stable, and it is not affected by the air volume.
7. The brush-less vortex fan is adopted, the air flow is adjustable, the range is large, and it can be adapted to various purposes.
8. The system is equipped with an automatic large air volume cooling function to extend the life of the heating element and protect the hot air handle.
9. It can interact with automation equipment online to realize information management.



Specification:

Model	BK862
Power/temperature range	2000W / 100°C-500°C
Air volume range / max air volume	1-120/250L/min
Size / weight	L260xW190xH130+5mm/ about 6.4kg
Working environment	0-40°C / 32-104°F
Storage environment/storage temperature	-20-80°C / -4-176°F / 35%-60%
Screen display	HD LCD display
Fan type	Brushless vortex fan
Temperature calibration	Digital calibration temperature
Temperature control method	Microcomputer temperature control
I/O control port	Sleep signal/alarm output/temperature OK signal

Accessories:



Air gun seat



Nozzle

BK863

Intelligent integrated hot air desoldering station

1. Use high-definition large LCD color screen display.
2. There are three working channels of CH1, CH2 and CH3, and the air volume and temperature of each channel can be set.
3. With password protection function and key lock function.
4. Real-time operation is convenient, with magnetic control switch control, the handle is placed on the handle frame and it will immediately enter sleep.
5. With automatic sleep function, parameters can be set in sleep state.
6. The sensor is closed loop, the microcomputer triggers the temperature control by zero crossing, the power is large, the temperature rises quickly, the temperature adjustment is convenient and accurate and stable, and it is not affected by the air volume.
7. The brush-less vortex fan is adopted, the air flow is adjustable, the range is large, and it can be adapted to various purposes.
8. The system is equipped with an automatic large air volume cooling function to extend the life of the heating element and protect the hot air handle.
9. It can interact with automation equipment online to realize information management.



BK1380 heating core



600M soldering iron tip



BK512 soldering iron stand



BK 906 handle

Accessories:



Air gun seat



Nozzle

Specification:

Model	BK863
Power/temperature range	1000W / 100°C-500°C 90W/100°C-480°C (handle)
Air volume range / max air volume	1~120/250L/min
Size / weight	L260xW190xH130+5mm/ about 5.5kg
Working environment	0~40°C / 32~104°F
Storage environment/storage temperature	-20~80°C / -4~176°F / 35%~60%
Screen display	HD LCD display
Fan type	Brushless vortex fan
Temperature calibration	Digital calibration temperature
Temperature control method	Microcomputer temperature control
I/O control port	Sleep signal/alarm output/temperature OK signal

BK969

Efficient constant temperature soldering station

1. The heating element is made of imported temperature-resistant materials with advanced technology, and has a long life;
2. The heating element is powered by a low-voltage AC source to ensure anti-static, no leakage and no interference;
3. 200 ~ 480°C temperature setting and control are stable and accurate;
4. The handle is light and handy, and there is no fatigue after long-term use;
5. Separate design, easy to place.



BK1321S heating core



900M soldering iron tip

Specification:

Intelligent lead-free soldering station	BK969
Operating Voltage	AC230V/50HZ
Operating temperature range	200~480°C
No-load standby power	≤5 W
Maximum instantaneous power	70W
Temperature stability (no load)	±2°C
Resistance of soldering iron tip to ground	<2Ω
Potential of the soldering iron tip to the ground	<2mV
Dimensions	L135xW107xH83mm
Correction method	Potentiometer calibration
Net weight/Gross weight	≈1.6Kg/≈1.8Kg

Accessories:



BK 905 handle



BK515 soldering iron stand

BK969A

Efficient constant temperature soldering station

- 1.The heating element is made of imported temperature-resistant materials with advanced technology, and has a long life;
- 2.The heating element is powered by a low-voltage DC source to ensure anti-static, no leakage and no interference
- 3.High temperature and anti-static wire;
- 4.Lightweight handle, no fatigue after long time use;
- 5.Split design, easy to place.



BK1321S heating core



900M soldering iron tip

Specification:

Intelligent lead-free soldering station	BK969A
Operating Voltage	AC100-240V.50/60HZ
Operating temperature range	200~480°C
No-load standby power	≤5 W
Maximum instantaneous power	60W
Temperature stability (no load)	±2°C
Resistance of soldering iron tip to ground	<2Ω
Potential of the soldering iron tip to the ground	<2mV
Dimensions	L135xW107xH83mm
Correction method	Potentiometer calibration
Net weight/Gross weight	≈0.8Kg/≈1.0Kg

Accessories:



BK 905 handle



BK515 soldering iron stand

BK969S

Efficient digital display constant temperature soldering station

1. Wide voltage power supply 100-240V;
2. High-definition large-screen display, compact body;
3. New drive circuit design, high temperature rise stability;
4. The heating element is short-circuit protected, and the sensor is abnormal.
5. Password protection to avoid illegal modification of settings.



BK1321S heating core



900M soldering iron tip

Specification:

Intelligent lead-free soldering station	BK969S
Operating Voltage	AC100-240V,50/60HZ
Operating temperature range	200~480°C
No-load standby power	≤5 W
Maximum instantaneous power	60W
Temperature stability (no load)	±2°C
Resistance of soldering iron tip to ground	<2Ω
Potential of the soldering iron tip to the ground	<2mV
Dimensions	L128xW104xH79mm
Net weight/Gross weight	≈0.8Kg/≈1.0Kg

Accessories:



BK 905 handle



BK515 soldering iron stand

BK969D

Efficient digital display constant temperature soldering station

1. Wide voltage power supply 100-240V;
2. High-definition large-screen display, compact body;
3. New drive circuit design, fast heating speed;
4. Adopt an integrated heating core, the sensor is abnormal prompt;
5. The handle adopts patented ergonomic design, and feels comfortable;
6. Password protection to avoid illegal modification of settings.



Specification:

Intelligent lead-free soldering station	BK969D
Operating Voltage	AC100-240V,50/60HZ
Operating temperature range	180~480°C
No-load standby power	≤5 W
Maximum instantaneous power	65W
Temperature stability (no load)	±2°C
Resistance of soldering iron tip to ground	<2Ω
Potential of the soldering iron tip to the ground	<2mV
Dimensions	L128xW104xH79mm
Net weight/Gross weight	≈0.8Kg/≈1.0Kg

Accessories:



T12 integrated heating core



LF008 Handle



BK515 soldering iron stand

BK969D+

Efficient digital display constant temperature soldering station

1. Wide voltage supply 100-240V;
2. High-definition large-screen display, compact body;
3. New drive circuit design, fast heating speed;
4. Microcomputer control, high temperature stability;
5. Adopt an integrated heating core, and the abnormal sensor often prompts;
6. The handle is designed with professional ergonomics and feels comfortable;
7. Password protection to avoid illegal modification of settings;
8. It has a sleep function to prevent oxidation of the soldering iron tip;



Specification:

Surface resistance tester	BK969D+
Operating Voltage	AC100-240V,50/60HZ
Temperature range	180°C ~480°C
No-load standby power	≤5w
Maximum instantaneous power	75W
Temperature stability (no load)	±2°C
Resistance of soldering iron tip to ground	≤2Ω
Voltage of soldering iron tip to ground	≤2mv
Dimensions	L128xw104xH79mm
Net weight/Gross weight	0.8Kg/1.0Kg

Accessories:



LF008 Handle



T12 integrated heating core



BK515 soldering iron stand

BK60/90

Efficient constant temperature soldering station

1. High-definition large-screen display, beautiful interface;
2. Short-circuit protection of heating core, abnormal sensor alarm;
3. New drive circuit design, fast heating speed;
4. Adopt aviation foolproof socket, good contact, high stability;
5. Three-level quick temperature adjustment, one key to rise to the preset temperature;
6. The handle adopts patented ergonomic design, and feels comfortable;
7. Microcomputer control, high temperature stability;
8. Use plug-in ceramic heating core, easy to replace;
9. It has a sleep function to prevent oxidation of the soldering iron tip;
10. Password protection to avoid illegal modification of settings.



BK1380 heating core



600M soldering iron tip

Specification:

Intelligent lead-free soldering station	BK60/90
Operating Voltage	AC230V/50HZ
Operating temperature range	200~480°C
No-load standby power	≤5 W
Maximum instantaneous power	60W/90W
Temperature stability (no load)	±2°C
Resistance of soldering iron tip to ground	<2Ω
Potential of the soldering iron tip to the ground	<2mV
Dimensions	L150xW130xH99mm
Correction method	Potentiometer calibration

Accessories:



BK 906 handle

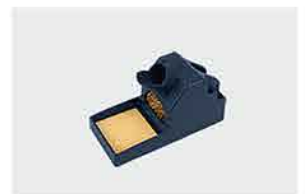

BK512 soldering iron stand

BK999/BK999.N

Only lead-free soldering station

- Large LCD display with simple and beautiful interface.
- Fast heating speed, only 3 seconds from 0 to 350°C.
- High temperature stability, no-load constant temperature deviation of $\pm 2^{\circ}\text{C}$.
- With sleep function, users can set sleep time.
- It can be equipped with an optional detection box to test the grounding resistance and leakage voltage of the soldering station in real time.



Extension cord and sleep cord



BK511 soldering iron stand

Specification:

Only lead-free soldering station	BK999/BK999.N
Operating Voltage	AC230V/50HZ
Operating temperature range	C245:100-480°C (BK999)
	C210:100-430°C C245:100-480°C (BK999.N)
Temperature stability	The temperature difference at no load is $\pm 2^{\circ}\text{C}$
Outside size	120×139×120mm
Net weight/Gross weight	2.5/2.8kg
Handle:	
Power consumption	AC26V 110W
Impedance between soldering iron tip and ground	<2Ω
Potential between soldering iron tip and ground	<2mV
Wire length	1.3m
Length (excluding wires)	250mm

Accessories:



LF998 handle (C210)



LF999 handle (C245)

Show description

The display box can be flexibly placed, and you can place it as you want. The large clear LCD screen looks tall and high-grade, easy to read and confirm.

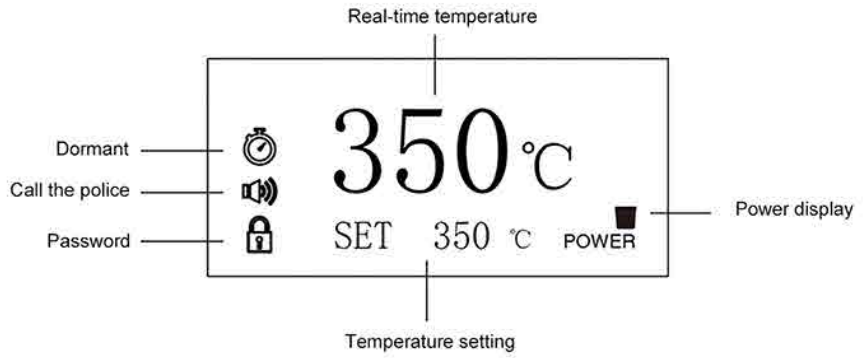
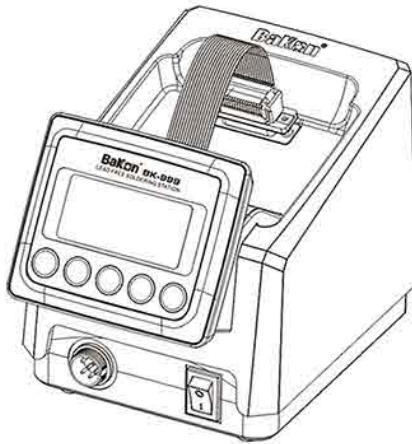

Connection between display box and host

Assemble the display box in the host slot

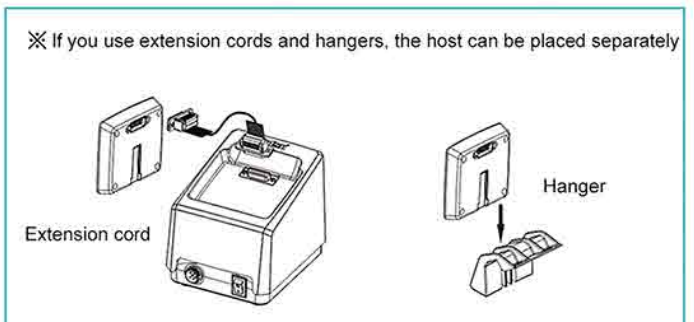

Connect	Measure mV	Measure Ω
<p>Test box</p> <p>Test box accessory line</p>		

BK1000

Eddy current heating lead-free soldering station

- 1.High-frequency eddy current heating, fast heating and reheating speed, more suitable for low-temperature welding places, to achieve high-quality lead-free welding;
- 2.Microcomputer control, button type temperature adjustment;
- 3.Password type temperature lock function, effectively guarantee the production process;
- 4.Anti-static design, a variety of soldering iron tips to choose from.



VH90 heating core



200M soldering iron tip

Specification:

Intelligent lead-free soldering station	BK1000
Operating Voltage	AC230V/50HZ
Operating temperature range	200-500°C
Maximum instantaneous power	90W
Temperature stability (no load)	±2°C
Resistance of soldering iron tip to ground	<2Ω
Potential of the soldering iron tip to the ground	<2mV
Dimensions	L145xW125xH95mm
Password lock function	Have

Accessories:



LF100 handle

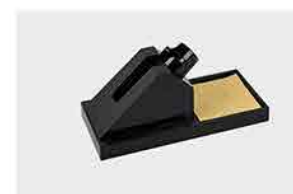

BK506A soldering iron stand

BK2000

Eddy current heating lead-free soldering station

- 1.High-frequency eddy current heating, fast heating and reheating speed, more suitable for low-temperature welding places, to achieve high-quality lead-free welding;
- 2.Microcomputer control, button type temperature adjustment;
- 3.Password type temperature lock function, effectively guarantee the production process;
- 4.Anti-static design, a variety of soldering iron tips to choose from.



VH90 heating core



200M soldering iron tip

Specification:

Intelligent lead-free soldering station	BK2000
Operating Voltage	AC230V/50HZ
Operating temperature range	200~500°C
Maximum instantaneous power	120W
Temperature stability (no load)	±2°C
Resistance of soldering iron tip to ground	<2Ω
Potential of the soldering iron tip to the ground	<2mV
Dimensions	L150xW130xH105mm
Password lock function	Have

Accessories:



LF201 handle



BK512 soldering iron stand

BK2000A

Eddy current heating lead-free soldering station

1. High-frequency heating principle, rapid heating and abundant heat;
2. The sensor is front-facing, sensitive to temperature, and instantaneous heat compensation;
3. Metal shell, high level of anti-static, equipped with cooling fan, low temperature of the host, can effectively reduce the life loss of electronic components;
4. If the soldering station is not used for 20 minutes, the host enters the dormant state, which can increase the service life of the soldering iron tip;
5. The password locks the temperature, which is more conducive to the control of the welding process;
6. Equipped with a temperature correction hole to correct the temperature at any time to meet the strict requirements of the special original device on the welding temperature;
7. If the soldering station is not used for 60 minutes, the host will automatically shut down, saving energy and no safety hazards.



VH90 heating core



200M soldering iron tip

Accessories:



LF202 handle



BK512 soldering iron stand

Specification:

Intelligent lead-free soldering station	BK2000A
Operating Voltage	AC230V/50HZ
Operating temperature range	50~600°C
Maximum instantaneous power	90W
Temperature stability (no load)	±2°C
Resistance of soldering iron tip to ground	<2Ω
Potential of the soldering iron tip to the ground	<2mV
Dimensions	L165xW130xH105mm
Password lock function	Have
Automatic sleep function	Have

BK2000S

Eddy current heating intelligent lead-free soldering station

1. High-definition large-screen display. Small body;
2. New type of driving circuit identification, fast heating speed;
3. Microcomputer control, high temperature stability;
4. Three-level quick temperature adjustment, one key rises to the preset temperature;
5. With sleep function. Prevent oxidation of the soldering iron tip;
6. Short-circuit protection of heating element, abnormal sensor alarm;
7. The handle adopts ergonomic design and feels comfortable;
8. Password protection to avoid the production process from being changed at will;



Specification:

Surface resistance tester	BK2000S
Operating Voltage	AC100-240V,50Hz/60Hz
Temperature range	100°C ~480°C
Maximum instantaneous power	120W
Temperature stability (no load)	±2°C
Resistance of soldering iron tip to ground	<2Ω
Potential of the soldering iron tip to the ground	<2mV
Dimensions	L180xw130xH104mm
Password lock function	Have
Sleep function	Have

Accessories:



LF202 handle



VH90 heating core



BK512 Soldering iron stand



200M soldering iron tip

BK3300A

Eddy current heating lead-free soldering station

1. The principle of high-frequency heating, rapid heating and abundant heat;
2. The sensor is front-facing, sensitive to temperature, and instantaneous heat compensation;
3. Plug-in design of heating element, easy and convenient to replace;
4. Metal shell, high anti-static level, equipped with cooling fan, low temperature of the host, which can effectively reduce the life loss of electronic original components;
5. If the soldering station is not used for 20 minutes, the host enters the dormant state, which can increase the service life of the soldering iron tip;
6. The password locks the temperature, which is more conducive to the control of the welding process;
7. Equipped with temperature correction holes to correct the temperature at any time to meet the strict requirements for the welding temperature of special original components;
8. If the soldering station is not used for 60 minutes, the host will automatically shut down, saving energy and no safety hazards.



VH300 heating core



500M soldering iron tip

Specification:

Intelligent lead-free soldering station	BK3300A
Operating Voltage	AC230V/50HZ
Operating temperature range	50~600°C(Multiple modes are available)
Maximum instantaneous power	150W
Temperature stability (no load)	±2°C
Resistance of soldering iron tip to ground	<2Ω
Potential of the soldering iron tip to the ground	<2mV
Dimensions	L215xW126xH106mm
Password lock function	Have
Automatic sleep function	Have

Accessories:



LF301 handle



BK512 soldering iron stand

BK3300S

Eddy current heating lead-free soldering station

1. High-definition large-screen display, compact body;
2. New drive circuit design, fast heating speed
3. Microcomputer control, high temperature stability;
4. Three-level quick temperature adjustment, one key to rise to the preset temperature;
5. Has a sleep function to prevent oxidation of the soldering iron tip
6. Short-circuit protection of heating element, abnormal sensor alarm;
7. The handle adopts ergonomic design and feels comfortable;
8. Password protection to avoid arbitrary modification of parameters set by different production processes.



Specification:

Surface resistance tester	BK3300S
Operating Voltage	AC100-240V
Temperature range	100°C ~480°C
Maximum instantaneous power	200W
Temperature stability (no load)	±2°C
Resistance of soldering iron tip to ground	<2Ω
Potential of the soldering iron tip to the ground	<2mV
Dimensions	L180xw130xH104mm
Password lock function	Have
Sleep function	Have

Accessories:



LF301 handle



VH300 heating core



BK512 Soldering iron stand



500M soldering iron tip

BK3500

Automatic lead-free soldering station

1. High-frequency eddy current heating, fast heating and reheating speed, high-quality lead-free soldering, can be equipped with a variety of long-life soldering iron tips;
2. Microcomputer control, super large screen display, button type temperature adjustment, digital temperature correction;
3. Fully automatic tin-out function, tin-out speed, tin-out amount, and tin-out time interval are all adjustable;
4. Two types of tin-out hoses can be configured, making it easier and more convenient to use. The long hose is suitable for movable welding, and the short hose is suitable for fixed welding;
5. It can be used as a lead-free soldering iron alone, and it can be equipped with a foot switch or a manual tin-out switch, and a universal adjustment mechanism, which makes the welding flexible and convenient.



VH90 heating core



Foot switch



200M soldering iron tip

Specification:

Intelligent lead-free soldering station	BK3500
Operating Voltage	AC230V/50HZ
Operating temperature range	200~500°C
Maximum instantaneous power	120W
Temperature stability (no load)	±2°C
Resistance of soldering iron tip to ground	<2Ω
Potential of the soldering iron tip to the ground	<2mV
Tin out speed	≈14mm/s~35mm/s
Tin output (automatic mode)	0.5~123mm
Tin out time interval	0~3.5s
Tin wire diameter	0.4, 0.5, 0.6, 0.8, 1.0, 1.2, 1.6
Tin return	Adjustable

Accessories:



LF302 handle



BK502 soldering iron stand

BK3600S

High-power lead-free soldering station with automatic tin feeding

1. Large screen display, with sleep function;
2. It can be used alone as a lead-free soldering station;
3. Smooth tin output, precise control and low noise;
4. The automatic and manual tin feeding mode can be switched naturally;
5. The tin delivery time, tin return time, tin delivery speed, interval time can be set.



Specification:

Automatic lead-free soldering station	BK3600S
Operating Voltage	AC100-240V,50Hz/60Hz
Temperature range	100°C ~480°C
Maximum instantaneous power	200W (maximum); Handle: 180W
Temperature stability (no load)	±2°C
Resistance of soldering iron tip to ground	<2Ω
Potential of the soldering iron tip to the ground	<2mV
Tin out speed	0.3-20mm/s
Out of tin length	0.3-200mm
Tin delivery time / tin delivery time interval	0.1-30s/0~10s
Back tin time	0-1s
Tin wire diameter	0.8~1.5mm
Tin out mode	Manual/semi-automatic/automatic

Accessories:



LF301 handle



VH300 heating core



BK500 Soldering iron stand



500M soldering iron tip

SBK936B

Constant temperature soldering station

1. Rotary temperature adjustment control, convenient and fast;
2. Split design, easy to place, a variety of nozzles to choose from, easy to replace;
3. The handle is designed to be light and handy, and it will not be fatigued after long-term use;
4. The handle adopts high temperature resistant accessories, which has a longer service life; the heating core plug-in design, the structure is reasonable, and the replacement is simple;
5. Without professional knowledge, ordinary employees can replace the heating element;
6. Maximize the production efficiency of the product.



C1321 heating core



900M soldering iron tip

Specification:

Intelligent lead-free soldering station	SBK936B
Operating Voltage	AC230V/50HZ
Operating temperature range	200-480°C
Maximum instantaneous power	65W
Temperature stability (no load)	±2°C
Resistance of soldering iron tip to ground	<2Ω
Potential of the soldering iron tip to the ground	<2mV
No-load standby power	≤5W
Dimensions	L170×W120×H93mm
Correction method	Potentiometer calibration

Accessories:



SBK907B handle



BK506A soldering iron stand

SBK936b

Constant temperature soldering station

1. Rotary temperature adjustment control, convenient and fast;
2. Split design, easy to place, a variety of nozzles to choose from, easy to replace;
3. The handle is designed to be light and handy, and it will not be fatigued after long-term use;
4. The temperature range is 200-480°C, and the temperature error becomes linear, all within the range of $\pm 2^{\circ}\text{C}$.



BK1326 heating core



900M soldering iron tip

Specification:

Intelligent lead-free soldering station	SBK936b
Operating Voltage	AC230V/50HZ
Operating temperature range	200-480°C
Maximum instantaneous power	40W
Temperature stability (no load)	$\pm 2^{\circ}\text{C}$
Resistance of soldering iron tip to ground	$< 2\Omega$
Potential of the soldering iron tip to the ground	$< 2\text{mV}$
No-load standby power	$\leq 5\text{W}$
Dimensions	L170×W120×H93mm
Correction method	Potentiometer calibration

Accessories:



SBK907b handle



BK506A soldering iron stand

SBK936D+

Efficient constant temperature soldering station

1. With three-digit one-stop digital display, the temperature is increased or decreased by $\pm 1^{\circ}\text{C}$;
2. The temperature range is 180-450 $^{\circ}\text{C}$, and the temperature error becomes linear, all within the range of $\pm 3^{\circ}\text{C}$;
3. The temperature calibration adopts the method of keying in the correction value;
4. With the function of free switching between Celsius/Fahrenheit;
5. With automatic sleep function;
6. Split design, easy to place, a variety of soldering iron tips to choose from, and easy to replace;



BK1321 heating core



900M soldering iron tip

Specification:

Intelligent lead-free soldering station	SBK936D+
Operating Voltage	AC230V/50HZ
Operating temperature range	200~480 $^{\circ}\text{C}$
Maximum instantaneous power	60W
Temperature stability (no load)	$\pm 2^{\circ}\text{C}$
Resistance of soldering iron tip to ground	$< 2\Omega$
Potential of the soldering iron tip to the ground	$< 2\text{mV}$
No-load standby power	$\leq 5\text{W}$
Dimensions	L141×W130×H90mm
Correction method	Potentiometer calibration

Accessories:



SBK907D+ handle



BK506A soldering iron stand

BK950D

Efficient constant temperature soldering station

1. Use trinity digital tube display;
2. Plug-in design of heating core, reasonable structure, easy to replace;
3. Split design, easy to place, a variety of nozzles to choose from, easy to replace;
4. Without professional knowledge, ordinary employees can replace the heating element.
5. The handle is designed to be light and handy, and it will not be fatigued after long-term use;



Specification:

Intelligent lead-free soldering station	BK950D
Operating Voltage	AC100-240V
Operating temperature range	180~450°C
Maximum instantaneous power	50W
Temperature stability (no load)	±2°C
Dimensions	L120×W60×H36mm
Correction method	Digital correction

Accessories:



T13 Integrated heating core
(Not standard, need to purchase)



LF007 handle



soldering iron stand

BK931

External heating electric soldering iron

1. The handle is made of nylon, which has high strength and good heat resistance;
2. Silicone sheath, heat insulation and non-slip, comfortable grip;
3. Black gold steel soldering iron tip, high temperature resistance, corrosion resistance. Wear resistance;
4. Small size, light touch, suitable for long-term operation;
5. Thick natural mica heating core, heating up quickly;
6. The power cord adopts the national standard three-core plug, high-soft material wire, high temperature resistance, aging resistance, soft and elastic.



Specification:

External heating electric soldering iron	BK931
Operating Voltage	AC220-240V
Maximum working temperature	420C±10°C
Maximum instantaneous power	30W
Temperature adjustment range	Not adjustable
Rewarming time	30S
Soldering iron tip specification/material	Solid head Φ3.8x70mm/black gold steel
Heater	Natural mica heating core
Net weight/Gross weight	150g/190g

Package:



BK932

Internal heating type adjustable thermostat electric soldering iron

1. The handle is made of PC transparent material, which has high strength and good heat resistance;
2. Constant temperature technology, the temperature range of 200°C-400°C can be adjusted arbitrarily;
3. Ceramic heating core, long life, fast heating, good temperature control;
4. Small size, light touch, suitable for long-term operation;
5. Stainless steel sleeve, no rust, fast heat dissipation;
6. Black gold steel soldering iron tip, high temperature resistance, corrosion resistance and abrasion resistance.



Specification:

Internal heating type adjustable thermostat electric soldering iron	BK932
Operating Voltage	AC220-240V
Maximum working temperature	450°C±10°C
Maximum instantaneous power	80W
Temperature adjustment range	200~450°C
Rewarming time	10s
Soldering iron tip specification/material	Pointed Φ8.1x56.8mm/black gold steel
Heater	PTC ceramic heater
Net weight/Gross weight	170g/210g

Package:



BK606S

Portable in-line digital display soldering iron

1. The handle is light and handy, so you will never feel tired after long-term use;
2. The design of the digital tube display, the temperature of the handle can be adjusted at any time, it is easy to place and more convenient to use;
3. Fast heating speed, high thermal efficiency;
4. Digital temperature correction function to achieve precise temperature welding;
5. With Fahrenheit/Celsius temperature conversion;
6. Suitable for personal and home maintenance.



Specification:

Portable in-line digital display soldering iron	BK606S
Operating Voltage	E118V: H (subject to the power sticker mark of the handle)
Temperature range	200°C ~450°C
Maximum instantaneous power	90W
Temperature stability (no load)	±2°C
Resistance of soldering iron tip to ground	<2Ω
Potential of the soldering iron tip to the ground	<2mV
Soldering iron tip to ground current	AC110v: ≤1mA; AC230v: ≤1.5mA
Total length	1.7M
Net weight/Gross weight	≈165g/≈286g

Accessories:



Soldering iron stand



900M soldering iron tip

BK607

Portable in-line digital display soldering iron

1. The handle is light and handy, so you will never feel tired after long-term use.
2. The design of the digital tube display, the temperature of the handle can be adjusted at any time, it is easy to place and more convenient to use.
3. Fast heating speed and high thermal efficiency.
4. Digital temperature correction function to achieve precise temperature welding.
5. With Fahrenheit/Celsius temperature conversion.
6. Suitable for personal and home maintenance.



Specification:

Portable in-line digital display soldering iron	BK607
Operating Voltage	AC 230V/50Hz
Operating temperature range	180~480°C
Power	90W
Resistance of soldering iron tip to ground	<2Ω
Voltage of soldering iron tip to ground	<2mV
Current of soldering iron tip to ground	≤1.5mA
Heating element	1370 heating core
Soldering iron tip	900M series
Power cord	1.5M
Total length	1.7M
Net weight/Gross weight	135g/256g

Accessories:



soldering iron stand

BK81

Efficient digital display constant temperature soldering station

1. Wide voltage power supply 100-240V;
2. High-definition large-screen display, compact body;
3. New drive circuit design, fast heating speed
4. Adopt an integrated heating core, the sensor is abnormal prompt;
5. The handle adopts patented ergonomic design, and feels comfortable
6. Password protection to avoid illegal modification of settings.



Specification:

Surface resistance tester	BK81
Operating Voltage	AC100-240V,50/60HZ
Temperature range	100°C ~480°C
No-load standby power	≤5w
Maximum instantaneous power	60W
Temperature stability (no load)	±2°C
Resistance of soldering iron tip to ground	<2Ω
Potential of the soldering iron tip to the ground	±5%
Dimensions	L128xw104xH79mm
Net weight/Gross weight	0.8Kg/1.0Kg

Accessories:



BK905 handle



BK1321S heating core



BK515 soldering iron stand



BK900 soldering iron tip

BK880

Efficient constant temperature hot air desoldering station

1. The handle is light and handy, so you will never feel tired after long-term use.
2. The design of the digital tube display, the temperature of the handle can be adjusted at any time, it is easy to place and more convenient to use.
3. Fast heating speed and high thermal efficiency.
4. Digital temperature correction function to achieve precise temperature welding.
5. With Fahrenheit/Celsius temperature conversion.
6. Suitable for personal and home maintenance.



Specification:

Portable in-line digital display soldering iron	BK880
Power consumption	Standby 1W
Air outlet device	Blower
Host	
Air volume	120L/Min
Size	(L)150x(W)130x(H)99mm
Weight	2.5kg
Spray gun	
Hot air temperature	100~500°C
Length	120cm
Weight	184g

Accessories:



Nozzle



BK853/853D heating core

BK881

Constant temperature two-in-one desoldering station

1. The large-screen display, small system size, and the welding handle is particularly light, which can cope with all kinds of welding. With the chip removal function, the maintenance work is more convenient;
2. Two-in-one design, saving working space, and each function can be used independently;
3. The visualized operation panel, which can adjust the air volume and temperature, is suitable for dismantling all kinds of chips such as QFP, SOP, PLCC or SOJ;
4. Built-in advanced microcomputer, digital adjustment/display system. ;
5. Automatic protection of heating materials (using pulse heating), which can better maintain the heating element, handle and wind head to extend the service life of the machine;
6. Anti-static design, especially safe for sensitive components;
7. Automatic cooling system to prevent overheating of heating elements.
8. High thermal efficiency, fast heating speed and stable temperature.



BK1380 heating core



BK853S heating core



600M soldering iron tip



Nozzle

Specification:

Comprehensive maintenance station	BK881
Display method	Smart LCD screen
Air outlet device	Blower
Host	Air volume 120L/Min
Size	(L)150x(W)130x(H)99mm
Weight	2.5kg
Power consumption	560w
Spray gun	Hot air temperature 100~500°C
Length	120cm
Weight	184g
Power consumption	90W
Welding part	Temperature range 200~480°C
Handle length	120cm

Accessories:



BK906 handle



BK512 soldering iron stand

BK850D

Smart hot air desoldering station

1. Air pump type air supply, rapid temperature rise and convenient temperature setting;
2. Using high-quality heating element, long life and low noise;
3. After turning off the heating switch, the automatic cooling system starts to operate to prevent the heating element from overheating;
4. Adjustable air volume and temperature, suitable for dismantling all kinds of QFP, SOP, PLCC or SOJ chips;
5. With Fahrenheit/Celsius display function;
6. After finishing the work, turn off the heating switch and display "---" to enter the standby state.



Specification:

Comprehensive maintenance station	BK850D
Output Power	550w
Input voltage	AC230V 50Hz
Airflow type	Air pump
Air flow volume	120L/min
Noise	<45dB
Working environment	-5~45°C
Temperature adjustment range	100~500°C
Display form	LED digital tube
Temperature stability	±3°C
Shape volume	L160xW141xH95mm
Weight	2.7Kg

Accessories:



Nozzle



BK853 heating core

BK701D

Smart hot air desoldering station

1. Use C1321 pluggable heating element, which is convenient for heating element replacement;
2. The heating element is made of imported temperature-resistant materials with advanced technology and has a long life;
3. Air pump type air supply, rapid temperature rise and convenient temperature setting;
4. Adjustable air volume and temperature, suitable for dismantling all kinds of QFP, SOP, PLCC or SOJ chips;
5. After turning off the heating switch, the automatic cooling system starts to operate to prevent the heating element from overheating;
6. With Fahrenheit/Celsius display function;
7. After finishing the work, turn off the heating switch and display "---" to enter the standby state.



BK853B heating core



C1321 heating core



900M soldering iron tip



Nozzle



Accessories:



BK907B handle



BK506A soldering iron stand

Specification:

Hot air desoldering station	BK701D
Output Power	700W
Input voltage	AC230V / 50Hz
Host	Working environment: -5~45°C
	Display form: LED digital tube
	Shape volume: L160xW141xH95mm
	Airflow type: Air pump
Spray gun	Air flow volume: 120L/min
	Temperature adjustment range: 100°C~500°C
	Temperature stability: ±3°C
	Temperature adjustment range: 100°C~480°C
Welding part	Temperature stability: ±2°C
	Welding tip to ground voltage/resistance: <2mV/ <2ohm

BK870A

Smart hot air desoldering station

1. Dynamic and real-time indication of the temperature of the heating element, adjust the temperature and 5 levels of adjustable air volume and have a storage function;
2. The air will be supplied automatically after the power switch is turned off. When the working temperature is lower than 100°C, the entire power supply will be disconnected;
3. Automatic protection of heating materials (using pulse heating), which can better maintain the heating element, handle and wind head to extend the service life of the machine;
4. Built-in advanced microcomputer, digital adjustment/display system;
5. Built-in temperature sensor, regardless of the air volume, the output temperature can remain stable;
6. The body and the handle are dual-regulated, which can accurately adjust the air volume and temperature to meet the desoldering needs of various chips.



Specification:

Hot air desoldering station	BK870A
Power consumption	520W
Air outlet device	Air pump
Host	
Air volume	23L/Min
Size	(L)225x(W)160x(H)145mm
Weight	4.0kg
Spray gun	
Power consumption	560w
Hot air temperature	100~480°C
Length	196cm
Weight	120g

Accessories:



Nozzle



BK853 heating core

SBK858D

Smart hot air desoldering station

1. Using high-quality sensors, microcomputer temperature control, LED display, high power, rapid heating, accurate and stable temperature, not affected by the air volume, and truly rapid desoldering.
2. The air flow is adjustable, the air volume is large and the air output is soft, the temperature is convenient to adjust, and it can be adapted to various purposes.
3. The handle is equipped with a magnetic control switch. As long as you pick up the handle, the system can quickly enter the working mode; put the handle back to the handle holder, and the sleep function will be automatically turned on.
4. The system is equipped with automatic cold air and accelerated cooling functions. When sleeping or manual cooling adjustment, it will automatically increase the air volume and quickly cool down to reduce the waiting time, which can extend the life of the heating element.
5. Using brushless fan, long life and low noise;
6. Using high-quality heating element, the efficiency can be doubled under the same power, which can effectively extend the working life of the heating element and save electric energy.
7. With software temperature compensation and hardware linear compensation.
8. Fahrenheit/Celsius display.
9. Sleep delay is turned on or off.
10. Turn on the marquee reminder on the screen when it is off, until it drops below 100°C and enters dormancy.



Specification:

Hot air desoldering station	SBK858D
Power consumption	550W±10%
Airflow type	Brushless fan soft wind
Temperature adjustment range	100~500°C / 212~932°F
Air flow volume	120L/min
Display form	LED digital (resolution 1°C/°F)
Temperature compensation	+50°C/±90°F
Handle length (including handle line)	≤120cm
Dimensions	L15xW10xH13.8cm
Body weight	1.55kg
Noise	<45dB
Working environment	-20~40°C
Storage environment	-20~80°C
Storage humidity	35%~45%

Accessories:



Nozzle



BK853S heating core

BK8586

Comprehensive maintenance station

1. Use C1321 pluggable heating element, which is convenient for heating element replacement;
2. The heating element is made of imported temperature-resistant materials with advanced technology and has a long life;
3. Air pump type air supply, rapid temperature rise and convenient temperature setting;
4. Adjustable air volume and temperature, suitable for dismantling all kinds of QFP, SOP, PLCC or SOJ chips;
5. After turning off the heating switch, the automatic cooling system starts to operate to prevent the heating element from overheating;
6. With Fahrenheit/Celsius display function;
7. After finishing the work, turn off the heating switch and display "---" to enter the standby state.



BK1327 heating core



BK853 heating core



900M soldering iron tip



Nozzle

Accessories:



BK907E handle



BK506A soldering iron stand

Specification:

Hot air desoldering station	BK8586
Display method	Digital Tube
Air outlet device	Blower
Host	Air volume 120L/Min
Size	(L)160x(w)95x(H)141mm
Weight	2.5kg
Power consumption	700w
Spray gun	Length 120cm
Temperature adjustment range	100°C-500°C
Weight	184g
Power consumption	60w
Welding part	Temperature range 200-480°C
Handle length	120cm

BK852

Smart hot air desoldering station

1. Air pump type air supply, rapid temperature rise and convenient temperature setting;
2. Adjustable air volume and temperature, suitable for dismantling all kinds of QFP, SOP, PLCC or SOJ chips;
3. Using high-quality heating element, long life and low noise;
4. After turning off the heat gun switch, the automatic cooling system starts to work to prevent the heating element from overheating;
5. The temperature can be adjusted and displayed in Fahrenheit/Celsius.



Specification:

Smart hot air desoldering station	BK852
Operating Voltage	AC 230V /50Hz
Temperature range	100~500°C
Air pump	Air pump flow
Maximum instantaneous power	550W
Display form	LED digital tube
Temperature stability	±3°C
Use environment	Temperature: -10~45°C; Humidity: 45~80%RH
Shape volume	L160xW259xH147mm
Net weight/Gross weight	3.2kg/3.7kg

Accessories:



Nozzle



BK853B heating core

BK852D+

Hot air desoldering station

1. Use C1321 pluggable heating element, which is convenient for heating element replacement;
2. The heating element is made of imported temperature-resistant materials with advanced technology and has a long life;
3. Air pump type air supply, rapid temperature rise and convenient temperature setting;
4. Adjustable air volume and temperature, suitable for dismantling all kinds of QFP, SOP, PLCC or SOJ chips;
5. After turning off the heat gun switch, the automatic cooling system starts to work to prevent the heating element from overheating;
6. The temperature has Fahrenheit/Celsius adjustment display function



BK907B handle

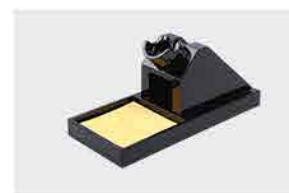

BK506A soldering iron stand



900M soldering iron tip



C1321 heating core

Specification:

Smart hot air desoldering station	BK852D+
Operating Voltage	AC 230V /50Hz
Temperature range	100~500°C
Air pump	Air pump flow
Maximum instantaneous power	700W
Display form	LED digital tube
Temperature stability	±3°C
Use environment	Temperature: -10~45°C; Humidity: 45~80%RH
Shape volume	L160xW259xH147mm
Net weight/Gross weight	4.2kg/4.7kg

Accessories:



Nozzle



BK853B heating core

BK373

Automatic tin feeding system

1. Automatic tin-out supporting system, suitable for a variety of soldering irons and soldering stations, and realize one-handed operation;
2. Fully automatic tin-out function, DIP switch design, tin-out speed, tin-out amount, and tin-out interval time are all adjustable, and there is an adjustable back tin function to reduce the waste of solder;
3. Automatic and manual control of tin output;
4. It can be equipped with foot-switch and manual tin-out switch.



373-2 Tin tube

Accessories:



373-1 Tin tube



Foot switch

Specification:

Automatic tin feeding system	BK373
Power consumption	5w
Motor power	DC24V 3.2w
Tin delivery time	0~3.5s
Delivery speed	14~35mm/s
Tin delivery	0~123mm
Tin return	Adjustable
Tin wire diameter	0.6, 0.65, 0.8, 1.0, 1.2, 1.6
Dimensions	215(L)x107(W)x110(H)mm
Weight	1.5kg

BK260XP

Smart smoke purifier

1. The purifier is specially designed for the purification of smoke and dust generated by soldering station operation, laser engraving, marking, etc.;
2. Imported high-pressure, low-noise fans are used, which can effectively absorb soot particles and maximize the service life of the filter element;
3. The control system adopts PWM speed regulation, which can realize continuous and precise adjustment of air volume according to the amount of smoke and dust generated; the control system is designed with an indicator light alarm device. When the filter element is blocked, the red indicator light will light up, prompting to replace the filter element;
4. The filtration system is composed of three parts: a pre-filter layer, a main filter layer and a gas filter layer. The pre-filter layer can absorb relatively large particles in the air flow to prevent the main filter layer from being blocked prematurely; the main filter layer is made of HEPA high-efficiency filter elements Composition, the HEPA high efficiency filter element has a filtration efficiency of 99.99% for 0.3 micron particles. The gas filter layer is composed of a chemical filter element, which can effectively remove harmful gases in the airflow.

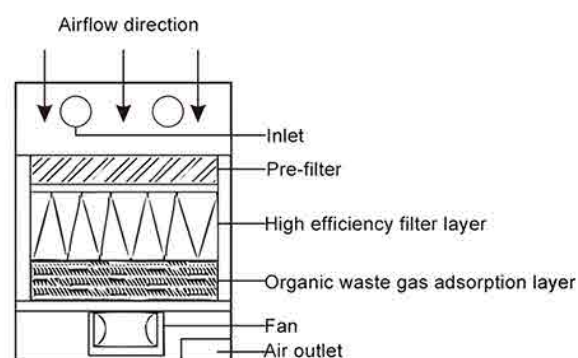

Applicable occasions for smoke filtration:

1. Soldering iron welding station
2. Tin furnace, wave soldering, reflow furnace
3. Laser welding, engraving, marking, cutting
4. Chemistry laboratory
5. Medical care, beauty, etc.

Specification:

Smart smoke purifier	BK260XP
Air inlet interface	Φ75mm*2 Flange
Input voltage	AC220V/110V; 50HZ/60HZ
Maximum power	200W
Wind speed	2x12m/s
Filter effect	0.3um/99.97%
Noise	< 50dB
Smoke pipe length	1.4M
System flow	2x155M ³ /h
Body size	L425xW250xH420mm
Host weight	14.5Kg



Principles of welding fume purification:

Generally, 95% of soldering fumes are particles that are volatilized by solder and flux at high temperatures. These particles float in the air and can be observed by the human eye under a certain amount of light, that is, the fumes that we can see. The other 5% is emitted as a gas in the air, which is invisible to our naked eyes, and these gases contain a large amount of acetaldehyde, formaldehyde, abietic acid, isocyanate, hydrocarbons and other harmful components. These particles and harmful gases will affect the health of operators and pollute the environment. The torch mist purification system is collected into the equipment of the smoke removal system through various suitable collectors (soldering iron pipes / smoking arms / smoking hoods, etc.) Row to the room.



Multi-station solder fume purification system:

The traditional soldering fume purification treatment on the production line is to use a smoker equipped with a layer of activated carbon net for purification; or to exhaust it to the outdoors through an exhaust system. The smoking device can only filter the solder fumes simply, but cannot effectively purify the fumes, which cannot meet the requirements of indoor air environmental protection.

The BK260XP fume purifier is specially designed for the purification of the fume generated by the soldering station. The soldering fume is pre-filtered by the fume purification system, the main filter, the gas filter and other multi-stage filtration; it can be directly discharged indoors to meet the indoor air quality standards, Eliminates the need for complex exhaust pipe engineering, because it does not exhaust air, saves indoor air-conditioning energy, and there is no indoor negative pressure caused by exhaust, which is more conducive to maintaining indoor cleanliness.

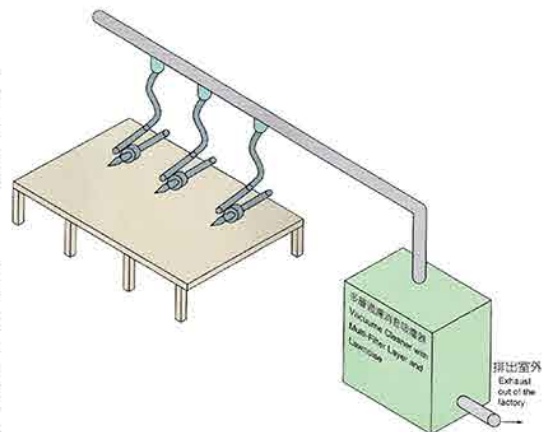

BK261

Smart smoke purifier

1. Brushless motor, low noise, high speed, stable operation, long life, low power consumption, high efficiency (zero maintenance of the motor, zero consumables);
2. Vortex fan design, fatigue resistance, stable operation, strong air volume, large suction force and high efficiency;
3. The model is equipped with a stepless speed regulator, and the air volume can be adjusted at will;
4. Multiple filtration design to ensure thorough filtration of toxic and harmful substances in the smoke, effectively protecting the environment and human health;
5. All filter elements can be replaced individually, which prolongs the service life of the filter element and reduces the cost of the filter element;
6. The installation is simple and convenient, and the machine can be used after disassembly and assembly, which is conducive to the cleanliness and beauty of the working space;
7. All metal frame structure, anti-collision and vibration;
8. Casters are installed at the bottom for easy movement.



Specification:

Smart smoke purifier	BK261
Inlet interface	Φ50
Input voltage	AC220V/110V; 50HZ/60HZ
Power	100W
System flow	235M ³ /h
Filter effect	> 0.3um/99.97%
Noise	< 50dB
Smoke pipe length	0.9~1.2M
Dimensions	L270xW220xH300mm
Host weight	8Kg

BK262

Smart smoke purifier

1. Brushless motor, low noise, high speed, stable operation, long life, low power consumption, high efficiency (zero maintenance of the motor, zero consumables);
2. Vortex fan design, fatigue resistance, stable operation, strong air volume, large suction force and high efficiency;
3. The model is equipped with a stepless speed regulator, and the air volume can be adjusted at will;
4. Multiple filtration design to ensure thorough filtration of toxic and harmful substances in the smoke, effectively protecting the environment and human health;
5. All filter elements can be replaced individually, which prolongs the service life of the filter element and reduces the cost of the filter element;
6. The installation is simple and convenient, and the machine can be used after disassembly and assembly, which is conducive to the cleanliness and beauty of the working space;
7. All metal frame structure, anti-collision and vibration;
8. Casters are installed at the bottom for easy movement.



Specification:

Smart smoke purifier	BK262
Inlet interface	Φ75*2
Input voltage	AC220V/110V; 50HZ/60HZ
Power	180W
System flow	2*139M ³ /h
Filter effect	0.3um/99.97%
Noise	< 55dB
Smoke pipe length	Φ75*1.4M
Dimensions	L425xW250xH420mm
Host weight	14.5Kg

BK493

Smart smoke purifier

1. The angle of the smoking instrument can be adjusted at will, the placement and movement are simple and convenient, the fan has low noise and long service life;
2. The filter is made of special urethane foam and refined activated carbon, which has a high absorption function;
3. There are two types of ordinary and dismantling static electricity;
4. The smoking instrument holder is placed on a desktop, which saves working space and is more convenient and free to adjust.
5. Efficiently and quickly eliminate toxic gases;



Specification:

Smoking device	BK493
Input voltage	AC220V/50Hz
Power consumption	DC24V 3.2w
Tin delivery time	30w
Inspiratory capacity	1.0m ³ /min
Outside size	167(L)× 101(W)× 182(H)mm
Weight	1.5kg
Accessories	Filter x 3PCS

BK101

Soldering iron comprehensive tester

1. Capable of measuring welding tip temperature, leakage voltage and grounding impedance;
2. Suitable for lead-free solder;
3. Equipped with the "MAX HOLD" function, which can record and display the maximum value of the test at the time;
4. You can simply and directly measure the leakage voltage and ground impedance.



Specification:

Soldering iron comprehensive tester	BK101	
Power consumption	Unit of measurement	1°C
	Measuring range	0~700°C
	Accuracy	±3°C (between 300~600°C)
Voltage	Sensor	K(CA) thermocouple
	Resolution	0.1mv
	Measuring range	0~40mV (AC)
Impedance	Accuracy	±(5%+1 digit)
	Resolution	0.1Ω
	Measuring range	0-40Ω
Show	Accuracy	±(5%+1 digit)
	LCD	3 1/2 LCD digital display
	The sensor is damaged	-/ooo
Power consumption	2W/220V	
Outside size	200(L)x 120(W)x 50(H) mm	
Weight	1kg	
Working environment	0~40 degrees, 20~90%RH relative humidity	

Accessories:



Temperature sensor

BK191

Soldering iron comprehensive tester

1. Use the CA sensor to accurately and quickly measure the temperature of the welding tip;
2. Clear digital display;
3. Special alloy coating, so that the sensor can resist corrosion and oxidation;
4. The sensor is easy to replace.



Specification:

Soldering iron comprehensive tester	BK191
Unit of measurement	1°C
Measuring range	0~ 700°C
Accuracy	±3°C (between 300~500°C)
Sensor	K(CA) thermocouple
Power supply	Dc9v thousand battery
Battery Life	≥150 hours
Ambient temperature	0~ 40°C, 20~80%RH relative humidity
Show	3 1/2 LCD digital display
Outside size	160(L)x 80(W)x 45(H) mm
Weight	200g

Accessories:



Temperature sensor

BK192

Soldering iron comprehensive tester

1. It can accurately measure the temperature of the welding tip, leakage voltage and ground impedance;
2. Meet the MIL-STD-2000 leakage voltage test standard;
3. The measurement is actually the root square (TRMS) value;
4. It can adapt to large temperature changes with high accuracy;
5. The test results can be output to the monitor.



Specification:

Soldering iron comprehensive tester	BK192	
Power consumption	Unit of measurement	1°C
	Measuring range	0 - 600°C
	Accuracy	± 3°C (between 300-600°C)
Voltage	Sensor	K(CA) thermocouple
	Resolution	0.1mV
	Measuring range	0 - 90mV (AC)
Impedance	Accuracy	±(5%+1 digit)
	Resolution	0.1Ω
	Measuring range	0-90Ω
Show	Accuracy	±(5%+1 digit)
	LCD	3 1/2 LCD digital display
	The sensor is damaged	-/000
Power consumption	1W/220V	
Outside size	200(L)× 120(W)× 50(H) mm	
Weight	1.1kg	
Working environment	0-40 degrees, 20-80%RH relative humidity	

Accessories:



Temperature sensor

External heat type lead-free soldering iron Tsui

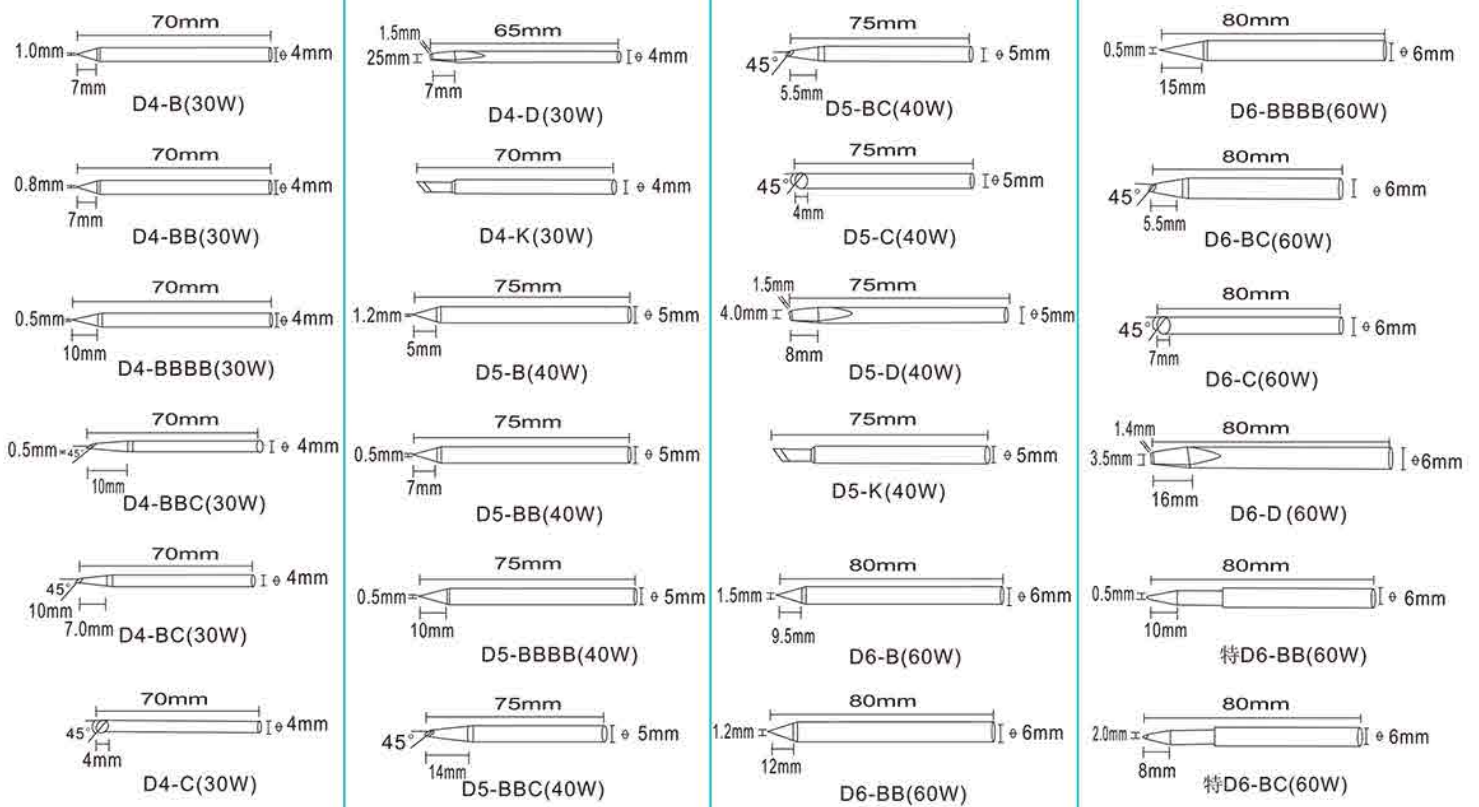

★ Suitable for 30W, 40W, 60W external hot soldering iron

200 series lead-free soldering tips

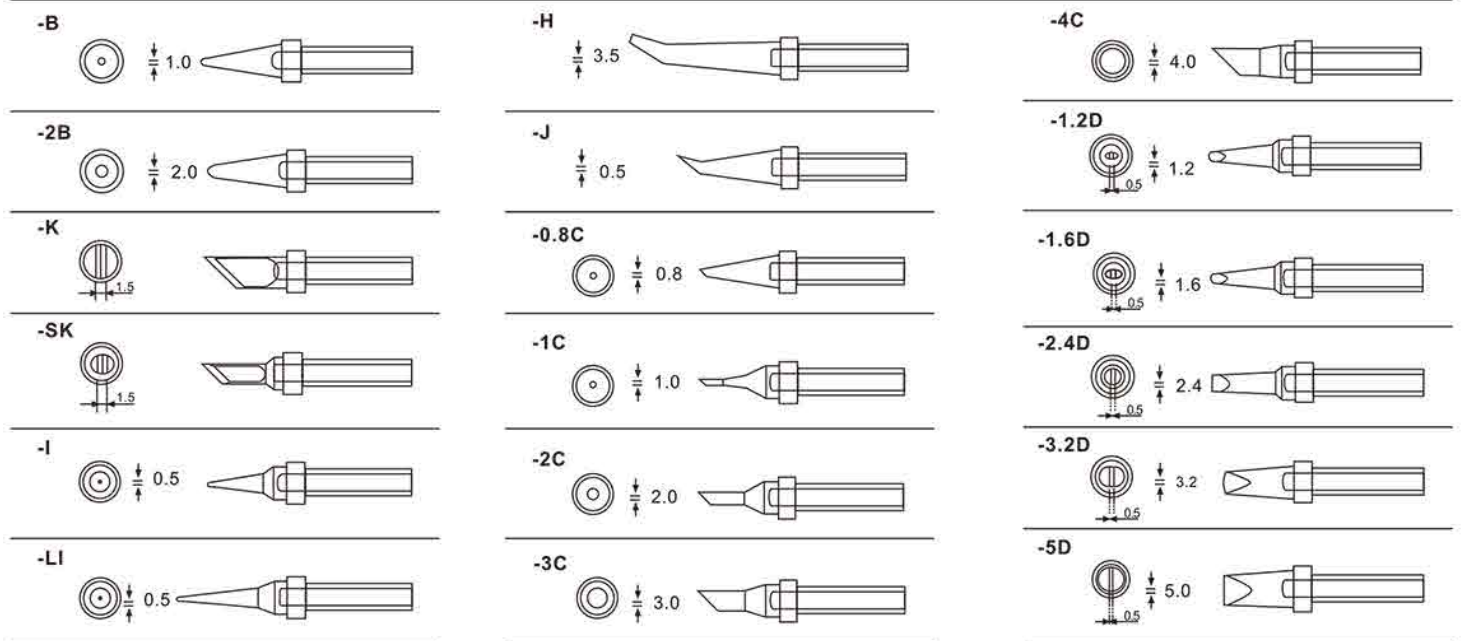

★ 200 series soldering iron head for BK1000, 2000, 2000A, 3200, 3500, 3800 Quick 3202, 3112, 3100, 3101, 3102, 203D, 203, 203H, 204, 204H, 303, etc.

501 series lead-free soldering tips

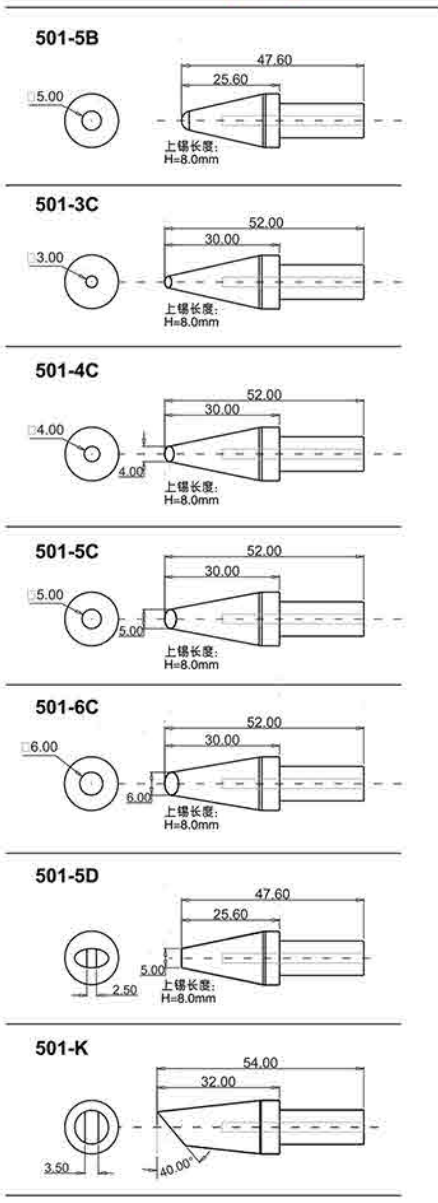

500 series lead-free soldering tips

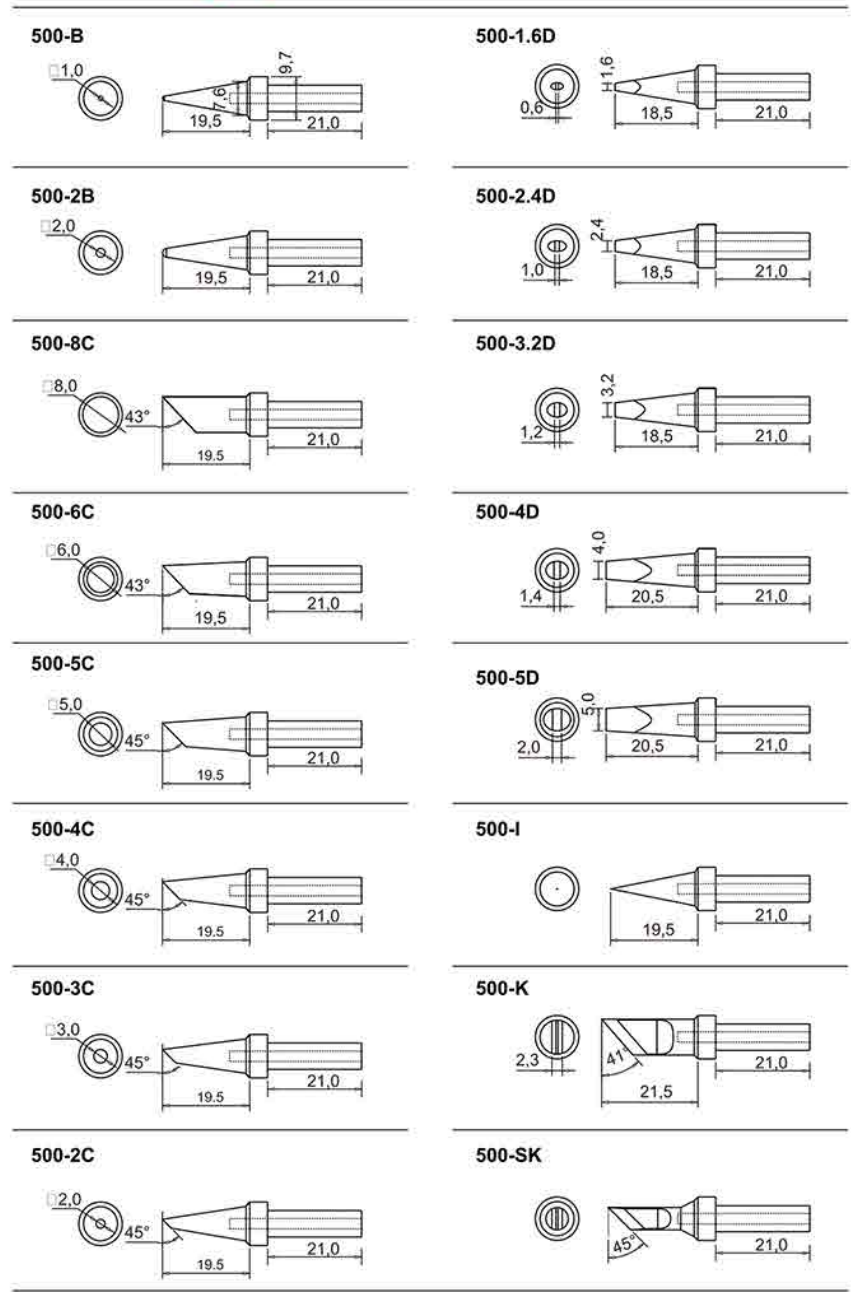

- ★ 501 series soldering tips compatible for BK3300, Quick206B and other lead-free soldering stations
- ★ 500 series soldering tips compatible for BK3300L, BK3300A, BK3600, Quick205 (flash) and other lead-free soldering stations

600 series lead-free soldering iron tip

600-B	
600-0.8D	
600-1.2D	
600-1.6D	
600-2.4D	
600-3.2D	
600-2C	
600-3C	
600-4C	
600-K	

Remarks: The soldering iron tip is BK60/90/881 and the handle is BK906, dedicated to the soldering station

900M series lead free soldering tips

900M-T-B		900M-T-H	
900M-T-BF2**		900M-T-0.5C	
900M-T-LB		900M-T-0.8C	
900M-T-SB		900M-T-1C	
900M-T-S4		900M-T-1CF*	
900M-T-0.8D		900M-T-1.5CF*	
900M-T-1.2D		900M-T-2C	
900M-T-1.6D		900M-T-2CF*	
900M-T-2.4D		900M-T-3C	
900M-T-3.2D		900M-T-3CF*	
900M-T-S3		900M-T-S10	
900M-T-1.2LD		900M-T-4C	
900M-T-2LD		900M-T-4CF*	
900M-T-1.8H		900M-T-S11	
		900M-T-I	
		900M-T-SI	
		900M-T-K	

★ 900M(φ6.5mm) series soldering tips compatible for 936 and 937 series soldering stations

T12/T13 series lead free tips. (heating element and tips 2 in 1)



T12/T13-B	T12/T13-B2	T12/T13-B3	T12/T13-B4	T12/T13-BL	T12/T13-BC1 T12/T13-BCF1												
T12/T13-BC2 T12/T13-BCF2	T12/T13-BC3 T12/T13-BCF3	T12/T13-C1	T12/T13-C4 T12/T13-CF4	T12/T13-D08	T12/T13-D12												
T12/T13-D16	T12/T13-D24	T12/T13-D4	T12/T13-D52	T12/T13-DL08	T12/T13-DL12												
T12/T13-DL32	T12/T13-DL52	T12/T13-I	T12/T13-IL	T12/T13-ILS	T12/T13-J02												
T12/T13-JL02	T12/T13-JS02	T12/T13-K	T12/T13-KF	T12/T13-KL	T12/T13-KR												
T12/T13-KU	T12/T13-1201	T12/T13-1202	T12/T13-1203	T12/T13-1204	T12/T13-1205												
T12/T13-1206	T12/T13-1207	T12/T13-1208	T12/T13-1209	T12/T13-1001	T12/T13-1002												
T12/T13-1003	T12/T13-1004	T12/T13-1005	T12/T13-1006	T12/T13-1007	T12/T13-1008												
T12/T13-1009	T12/T13-1010	T12/T13-1401	T12/T13-1402	T12/T13-1403	T12/T13-1404												
T12/T13-1405	T12/T13-1406	T12/T13-BZ	T12/T13-B2Z	T12/T13-BC1Z T12/T13-BCF1Z	T12/T13-BC2Z T12/T13-BCF2Z												
T12/T13-BCM2	T12/T13-BC3Z T12/T13-BCF3Z	T12/T13-BCM3	T12/T13-4C4Z T12/T13-4CF4Z	T12/T13-D12Z	T12/T13-D16Z												
T12/T13-D24Z	T12/T13-D4Z	T12/T13-KFZ	T12/T13-KRZ	T12/T13-WB2	T12/T13-WB08												
T12/T13-WB12	T12/T13-WB16	T12/T13-WD52	T12/T13-WI	<table border="0"> <tr> <td> B Type</td> <td> BC Type</td> <td> C Type</td> <td> D Type</td> </tr> <tr> <td> J Type</td> <td> K Type</td> <td> SMD Type (Quadrilateral)</td> <td> I Type</td> </tr> <tr> <td> SMD Type (Spatula type)</td> <td> Special purpose type</td> <td> High heat capacity type</td> <td> SMD Type (Pipe type)</td> </tr> </table>		B Type	BC Type	C Type	D Type	J Type	K Type	SMD Type (Quadrilateral)	I Type	SMD Type (Spatula type)	Special purpose type	High heat capacity type	SMD Type (Pipe type)
B Type	BC Type	C Type	D Type														
J Type	K Type	SMD Type (Quadrilateral)	I Type														
SMD Type (Spatula type)	Special purpose type	High heat capacity type	SMD Type (Pipe type)														

★ The soldering iron tip is only tinned on the bevel

★ T12 compatible for 942, BK950, FX-951, FX-952 lead-free soldering station

910&911
&911G
Soldering iron tip



D type

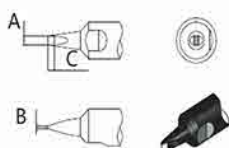

	A	B	C
-16D	ø1.6	0.6	1.5
-20D	ø2.0	0.8	1.5
-24D	ø2.4	0.8	1.5
-30D	ø3.0	1	2
-40D	ø4.0	1.2	2.5

PC type

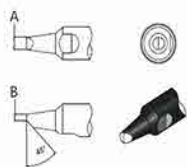

	A	B
-10PC	ø1.0	0.5
-13PC	ø1.3	0.65
-16PC	ø1.6	0.8
-20PC	ø2.0	1
-24PC	ø2.4	1.2
-30PC	ø3.0	1.5
-40PC	ø4.0	2

DV1 type

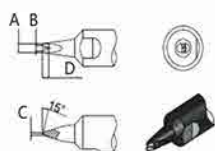

	A	B	C	D
-16DV1	ø1.6	1	0.6	1.5
-20DV1	ø2.0	1.2	0.8	1.5
-24DV1	ø2.4	1.4	0.8	1.5
-30DV1	ø3.0	1.6	1	2
-40DV1	ø4.0	2	1.2	2.5

DV2 type

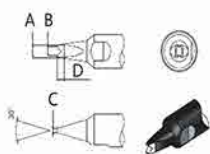

	A	B	C	D
-16DV2	ø1.6	1	0.6	1.5
-20DV2	ø2.0	1.2	0.8	1.5
-24DV2	ø2.4	1.4	0.8	1.5
-30DV2	ø3.0	2.2	1	2
-40DV2	ø4.0	3	1.2	2.5

N type

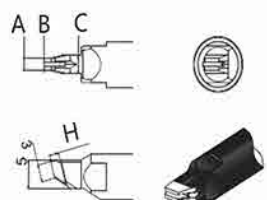

	A	B	C	H
-22N08H18	2.2	0.8	3.2	1.8
-28N08H15	2.8	0.8	3.6	1.5
-24N10H20	3.0	1	4	2
-30N12H23	3.2	1.2	4	2.3
-40N12H28	3.2	1.2	4	2.8

Nozzle series

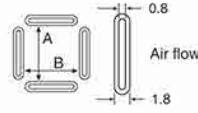

* Specification is IC size

Unit : mm

Can cooperate with vacuum suction function

QFP	SOP	PLCC	SOJ	BGA(CSP)			
A1125B QFP 10 x 10 A:10.2 B:10.2	A1126B QFP 14 x 14 A:15.2 B:15.2	A1127B QFP 17.5 x 17.5 A:19.2 B:19.2	A1128B QFP 14 x 20 A:15.2 B:21.2	A1129B QFP 28 x 28 A:29.7 B:29.7	A1135B PLCC 17.5 x 17.5 (44 Pins) A:18.5 B:18.5	A1136B PLCC 20 x 20 (52 Pins) A:21 B:21	
A1137B PLCC 25 x 25 (68 Pins) A:26 B:26	A1138B PLCC 30 x 30 (84 Pins) A:31 B:31	A1139B PLCC 12.5 x 7.1 (18 Pins) A:6.9 B:14	A1140B PLCC 11.5 x 11.5 (28 Pins) A:13 B:13	A1141B PLCC 11.5 x 14 (32 Pins) A:15 B:13	A1180B BQFP 17 x 17 A:18.2 B:18.2	A1181B BQFP 19 x 19 A:19.2 B:19.2	
A1182B BQFP 24 x 24 A:24.2 B:24.2	A1184B SOJ 18 x 8 A:19 B:10	A1185B TSOL 13 x 10 A:11.9 B:10	A1186B TSOL 18 x 10 A:18.2 B:11.7	A1187B TSOL 18.5 x 8 A:18.5 B:10	A1257B SOP 11 x 21 A:11.7 B:21	A1258B SOP 7.6 x 12.7 A:8.2 B:11.7	
A1259B SOP 13 x 26 A:13.5 B:26	A1260B SOP 8.6 x 18 A:8.7 B:18	A1261B QFP 20 x 20 A:20.2 B:20.2	A1262B QFP 12 x 12 A:12.2 B:12.2	A1263B QFP 28 x 40 A:27.7 B:39.7	A1264B QFP 40 x 40 A:40.2 B:40.2	A1265B QFP 32 x 32 A:32.2 B:32.2	
A1188B PLCC 9 x 9 (20 Pins) A:11 B:11	A1189B PLCC 34 x 34 (100 Pins) A:36.5 B:36.5	A1203B QFP 35 x 35 A:35.2 B:35.2	A1214B SOJ 10 x 26 A:12 B:25.9	A1215B QFP 42.5 x 42.5 A:42.5 B:42.5	A1470 BGA 8 x 8 A:9 B:9	A1471 BGA 12 x 12 A:13 B:13	
A1472 BGA 13 x 13 A:14 B:14	A1473 BGA 15 x 15 A:16 B:16	A1474 BGA 18 x 18 A:19 B:19	A1475 BGA 27 x 27 A:28 B:28	A1476 BGA 35 x 35 A:36 B:36	A1477 BGA 38 x 38 A:39 B:39	A1478 BGA 40 x 40 A:41 B:41	

Not compatible with vacuum suction

A1124B* Single ϕ 2.5 ϕ 2.5 (I.D)	A1130* Single ϕ 4.4 ϕ 4.4 (I.D)	A1131* SOP 4.4 x 10 A:4.8 B:10	A1132* SOP 5.6 x 13 A:5.7 B:13	A1133* SOP 7.5 x 15 A:7.2 B:15	A1134* SOP 7.5 x 18 A:7.2 B:18	A1142B* Bent Single 1.5 x 3 A:1.5 (I.D) B:3 (I.D) 45°
A1183* SOJ 15 x 8 A:8 B:15	A1190* Dual Single 2.5 x 9.5 ϕ 2.5 (I.D)	A1191* SIP 25L A:26 B:2	A1192* SIP 50L A:52.5 B:2	A1325* Dual Single ϕ 1.5 x 5-10 Adjustable Pitch A:5 B:10 Adjustable nozzle distance ϕ 1.5 (I.D) The pitch between the two nozzles is adjustable		

BK218

Spring automatic separator

1. The current customers who use springs that we have contacted generally report that spring winding is a very headache, so our company develops a spring separator according to the needs of customers, specifically for the spring winding problem!
2. The spring separator is suitable for AC 50 Hz and 220 volt circuits. Generally used in spring measurement, screening and separation work before spring assembly;
3. Its function is to separate the intertwined springs into single ones. Minus the manual peeling of the spring;
4. This equipment separates cylindrical springs within the range of spring wire diameter p0.45-p1.5mm, spring outer diameter p2-p12mm, free height 2-20mm;
5. Its characteristics: small size, light weight, convenient placement, safe and reliable use, fast separation speed, no deformation of the spring after separation, and no coating falling off.



Specification:

Spring automatic separator	BK218
Scope of application	Helical (no extension) spring
Voltage	AC220V
Outer diameter	2~12mm
Free length	2~20mm
Wire diameter	0.45~1.5mm

BK10/50/100

Digital Torque Tester

1. Automatic shutdown (automatically shutdown after 10 minutes (OFF));
2. When setting the tool torque, the peak value display will remain until reset to ensure accuracy;
3. The maximum, minimum and average torque can be calculated;
4. Clockwise and counterclockwise, both elastic and tight torque can be tested;
5. The torque value display automatically returns to zero;
6. Measured in the counter-clockwise direction, the data is displayed as a negative value;



Specification:

Soldering iron comprehensive tester	BK10	BK50	BK100	
	N.m	0.015-1.0000	0.075-5.00	0.15-10.00
Peak range	Lbf.in	0.15-9.0	0.75-45.0	1.5-90.0
	Kgf.cm	0.15-10.00	0.75-50.0	1.5-100.0
Precision	Less than $\pm 0.5\%$			
Model	Highest, Full Course and First Highest			
Volume (mm)	123× 230 × 65			
Weight (kg)	1.8			
Power supply	5 1.2v NiCd batteries, 1200mAh			
Charging time	6 hours			
Continuous use time	8 hours			
Transformer	Input AC110V or 220 V, output DC7.25V/120mA			

PC-linked software:

1. Real-time torque data collection
2. Draw the torque curve
3. Test data can be exported to EXCEL
4. Generate test report

BK8016/BK8020

Digital display high temperature hot air gun

1. For work that requires strict desoldering temperature, adjust the required temperature, such as repairing mobile phones (250-280°C), blow-welding BGA components, plastic holders or softening other welding materials, removing old paint or painting. (Cement paint, enamel paint and mineral paint cannot be removed by heating);
2. Heat shrinkable packaging film, curved plastic tube;
3. Polyethylene used for shrinking and joining metals, removing self-adhesive stickers and decorations;
4. Solve rusty or too tight metal nuts and screws;
5. Before treating grease stains or replacing old grinding powder, it can be softened first.



BK8016



BK8020

Applies to:

The high-temperature hot air gun is suitable for melting tin, thawing, paint removal, shrink tube heating, laboratory utensils dry and clean, liquid heat transfer, catalytic adhesive, shrink packaging, softening plastic sheets, carpet stitching, removing thread ends in the clothing industry, and quantitative output Heat and all non-fire high temperature heating, there are a variety of nozzles and accessories to choose from, the output power is up to 2000W, the temperature is up to 600 degrees, and the efficiency is high and easy to operate. The special temperature adjustment system can adjust different temperatures at will.

Specification:

Digital display high temperature hot air gun	BK8016	BK8020
Power consumption	1600W	2000W
Reference temperature	60-600°C	50-630°C
Air flow volume	200L-450L/min	250L-500L/min
Outside size	245(L)x185(W)x70(H)mm	245(L)x185(W)x70(H)mm
Weight	520g	550g
Insulation class	□ / II	□ / II

BK715

Automatic screw feeder

1. When taking out the screw, for the position of the screw head, just put the batch head into the batch head guide and slide down along the guide; then pull the screw out toward the front;
2. Compared with the traditional screw plate, each screw can save 1.4 seconds, and the productivity can reach 6 times!
3. Easy to operate, even novices can learn how to operate immediately;
4. It is not necessary to align the screws, just put the screws into the feeding chamber in batches; ·Widely suitable for various types and lengths of screws;
5. The size is small and does not take up space;
6. Automatically guide, cooperate with electric batch or wind batch,
7. No jam screw phenomenon! It is an ideal product to replace the traditional screw machine.



No jam screw phenomenon:

The screws move into the bucket in the drum, and all the screws that have not entered the track are removed to the drum and enter the next cycle. The working speed can be adjusted freely, and the speed can be changed by adjusting the vibration intensity. When the screw reaches the picking position, it will not jitter back and forth and affect the work efficiency!

Fault alarm function:

Feeding and vibration drive are independently controlled, and the ideal delay stop time can be set freely. When an abnormal situation occurs, the screw machine will start the fault alarm function | The operation is quite simple!

Specification:

Automatic screw feeder	BK715
Suitable for screws	Various types of screws include screws with washers (L=20MM)
Output speed	2 grains/sec
Track adjustable range	1.0~5.0mm
Input voltage	DC12V
Weight	1.5kg (net weight)
With accessories	DC power supply (DC12V)
Physical dimension	180(L)*125(W)*150(H)mm

BK725A

Automatic screw feeder

1. Improve on the basis of ordinary screw machine, increase counting function, work stably! More cost-effective!
2. New digital panel operation, beautiful and generous!
3. The number can be set arbitrarily from 0-999, and the number is clear at a glance! Automatically alarm and stop when the amount is reached!
4. The counting function cycle can be automatically/manually switched!
5. Inherit the advantages of ordinary screw machines, stable performance, adjustable rails without screwing, and the operation is as simple as other screw machines!
6. The size of the screw is adjustable from 1 to 5mm.



No jam screw phenomenon:

The screws move into the bucket in the drum, and all the screws that have not entered the track are removed to the drum and enter the next cycle. The working speed can be adjusted freely, and the speed can be changed by adjusting the vibration intensity. When the screw reaches the picking position, it will not jitter back and forth and affect the work efficiency!

Fault alarm function:

Feeding and vibration drive are independently controlled, and the ideal delay stop time can be set freely. When an abnormal situation occurs, the screw machine will start the fault alarm function | The operation is quite simple!

Specification:

Automatic screw feeder	BK725A
Suitable for screws	Various types of screws include screws with washers (L=20MM)
Output speed	2 grains/sec
Track adjustable range	1.0~5.0mm
Input voltage	DC12V
Weight	1.5kg (net weight)
With accessories	DC power supply (DC12V)
Physical dimension	180(L)*125(W)*150(H)mm

BK401/402/403

DC Ion fan

This ion fan is the latest DC ion fan developed by our company that is currently the most cutting-edge in the international market. Several superior performances: low power consumption and high efficiency (the DC fan has a full load working power of 20W, which is only equivalent to the power of a small energy-saving lamp; the voltage balance performance is stable, when the test distance (30CM), the DC fan eliminates the static ion balance. The temperature can reach within $0\pm 5V$ (Grade A), which is the highest level of antistatic ability. This DC ion fan has a strong antistatic ability, which can eliminate 1KV static electricity to within 100V within 1 second.

This ion fan is used to eliminate static electricity generated by the human body, equipment, sensitive electronic components, etc. It is professionally designed and manufactured for effective static elimination and static protection. It is suitable for anti-static dust-free workshops, electronic warehouses, laboratories and other static protection places .



Single outlet

Double outlet



Three outlets



Structural design features:

1. The front cover of the product body adopts a double-layer detection and isolation design, which can truly and stably detect unbalanced voltage and isolate external interference source signals;
2. The internal design of the machine adopts the front-mounted DC fan and the rear-mounted design layout of the high-pressure launcher. This design allows the positive and negative ions of high-voltage ionization to be fully mixed by the fan. Better elimination of static electricity;
3. The rear cover of the fuselage adopts a bullet buckle protection design. This design can facilitate the disassembly of the protective cover and immediately clean the high-pressure launch needle and fan blades;
4. The built-in circuit switch is designed to cut off the working power immediately after the protective cover is removed to protect the maintenance personnel from high-voltage electric shocks;
5. The launching pin is designed as a plug-in type that is easy to replace. The launching frame can be easily and conveniently replaced without replacing the launching pin. At the same time, it saves maintenance costs.
6. Automatic cleaning device, convenient for ion needle maintenance.

Specification:

DC ion fan	Bk401	Bk402
Input voltage	AC230V/50HZ	AC230V/50HZ
Power	20W	45W
Single port air volume	Max95CFM(Adjustable)	Max95CFM(Adjustable)
Ion balance	0±5V	0±5V
Time to eliminate static electricity	≤1.2s	≤1s
Effective coverage area	40x90cm ²	70x90cm ²
Working humidity	< 75%RH	< 75%RH
Working temperature	-5~45°C	-5~45°C
Packing dimension	290(L)X220(W)X175(H)mm	700(L)X210(W)X180(H)mm
Weight	1.8Kg	4.5Kg

Specification:

DC ion fan	Bk403
Input voltage	AC230V/50HZ
Power	50W
Single port air volume	Max95CFM(Adjustable)
Ion balance	0±5V
Time to eliminate static electricity	≤1s
Effective coverage area	100x90cm ²
Working humidity	< 75%RH
Working temperature	-5~45°C
Packing dimension	1045(L)X210(W)X180(H)mm
Weight	6.4Kg

Eliminate static test results:

Operating voltage:AC230V	Test voltage:1KV-100V	Ambient temperature:25°C	
Test distance(cm)	30	60	90
Time to eliminate static electricity(s)	1	2.5	5
Ion balance(v)	0±5	0±4	0±3
Wind speed (level 1~3)	5	5	5

※ Note: The test results will vary due to the humidity and cleanliness of the test environment
time to eliminate static electricity (without dust-proof net)

Annex:

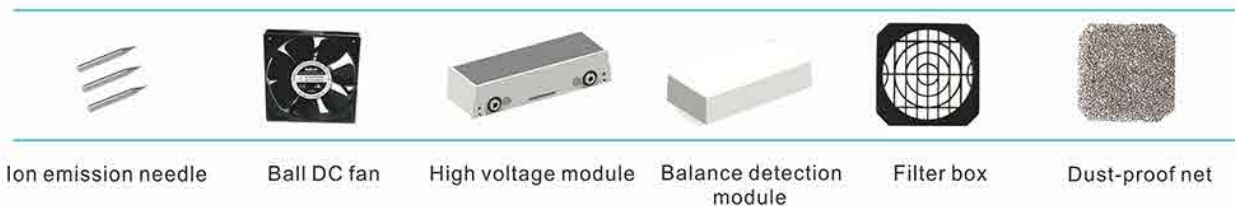

Ion emission needle

Ball DC fan

High voltage module

Balance detection module

Filter box

Dust-proof net

BK-FS460

Inductive ion wind snake

BK-FS460 Ion Wind Snake can generate a large amount of airflow with positive and negative charges, which is blown out by the compressor at high speed, which can neutralize the charge on the object. When the charge on the surface of the object is negative, it will attract the air-flow. When the charge on the surface of the object is positive, it will attract the negative charge in the airflow, so that the static electricity on the surface of the object is neutralized to achieve the purpose of eliminating static electricity. The high-speed compressed airflow can blow away the stubborn dust.

1. Automatic sensor switch (standard distance: 10-30cm);
2. Combination of static and dust removal;
3. The body is small and lightweight;
4. Adjustable air valve can be added to adjust the air volume arbitrarily;
5. Ion balance 0V+15V;
6. The snake tube can be deformed at will to point the nozzle to the target position, and the ion air flow can be directly blown to the target surface without manual operation;
7. It can blow ions directly to the target surface through high-speed airflow;
8. Ionic air volume can quickly eliminate static electricity and prevent re-adhesion to objects.



Specification:

Inductive ion wind snake	BK-FS460
Operating voltage	220V/50Hz
Current consumption	≤200mA
Operating temperature	0~50°C
Compressed air pressure	0.5-0.7/Mpa
Air velocity	10m/sec
Packing box size	247×190×295mm
Weight	3.1kg

BK-GS4000/BK5500

Ion air gun/Ion air nozzle

The ionizing air gun/air nozzle is an efficient static elimination device. Through the high-pressure airflow, a large number of positive and negative ions generated by the ion generating device are quickly blown to the area to be electrostatically removed, neutralizing the electrostatic charge accumulated on the object, and high-speed ions The airflow blows away the dust particles attracted by static electricity, and prevents them from attracting dust particles again; widely used in electronic assembly, microelectronics manufacturing, biological products, pharmaceuticals, injection molding, printing and other industries.

1. The ion balance value can reach $\pm 10V$, which can quickly eliminate static electricity on charged objects;
2. Built-in silencer system, low noise;
3. Stable ion balance, external adjustment, simple and convenient;
4. High voltage adopts capacitive coupling method, which is safe and reliable.

BK5500 Nozzle



BK5500-2 Sensor Nozzle



GS4000 Iron Gun



Specification:

Ion wind gun	BK-GS4000/BK5500
Input voltage	AC230v 50HZ (110V can be directly converted)
Current consumption	$\leq 350\mu A$
The output voltage	4.0KVAC
Ion balance	Adjusted to within $\pm 10V$ when leaving the factory ($\leq 300mm$)
Air volume	$\leq 3.3m^3/min$
Ozone production	0.03ppm or less ($\leq 150mm$)
Operating temperature	0-50°C
Outer diameter of trachea	6mm
Packing box size	250(L)x 248(W)x 50(H)mm
Weight	2.65kg

In addition to static test results:

Operating air pressure: 0.5-0.7Mpa, test voltage: 5KV-500V, ambient				
Ambient temperature	25°C			
Test distance (CM)	30	60	90	120
Static elimination time (S)	1.0	1.7	2.9	5.0
Ion balance (V)	0 \pm 10	0 \pm 9	0 \pm 7	0 \pm 5
Air volume	$\leq 3.3m^3/min$			

※Remarks: The test data is 30cm away from the front panel, and the test result will vary depending on the ambient air temperature and humidity during the test will vary.

BK698A

Human body comprehensive tester

BK698A two-foot human body comprehensive tester is designed to measure the comprehensive resistance of the human body (including the resistance of the human body, wrist straps and shoes) and is designed with an intuitive LED display. This instrument can detect and alarm when the comprehensive resistance of the human body is greater than 10^9 or less than 10. The two-foot human body comprehensive tester is equipped with 750K Ω -10M Ω circuit (for testing wrist straps) and 750K Ω -100M Ω circuit (for testing shoes), This instrument is ideal for testing wrist straps and shoes.

1. This product can quickly test ESD equipment, and three independent devices (wrist strap, left shoe, right shoe) can complete ESD testing at one time;

2. Three respectively three status displays:

LO (below the set value);

PASS (within the set value range);

HI is higher than the set value) with alarm function.



Tester

Specification:

Human body comprehensive tester	BK698A
Operating environment	0~31C, 0%-90%RH
Size	Instrument: 142.5x82x39mm Bracket: 400x250x800mm Pedal: 400x450mm
Net weight	5.5kg
Height adjustment range of tester	900~1470mm
Shoe test	750K Ω -100M Ω
Wrist strap test	750K Ω -10M Ω
Indicator light (shoes)	750K Ω -100M Ω Green(Pass)/ $\geq 110M\Omega$ 或 $\leq 740K\Omega$ Red(Fail HI/LO)
Indicator light (wrist strap)	750K Ω -10.5M Ω Green(Pass)/ $\geq 11.5M\Omega$ 或 $\leq 740K\Omega$ Red(Fail HI/LO)

BK699A

Heavy hammer type surface resistance tester

The BK699A digital weighted surface resistance tester measures the resistance of anti-static products to detect the anti-static ability of anti-static products. It follows the ASTM standard D-257 test method. When testing, only two heavy hammers are needed. The surface of the measured object and press the red button, the instrument will display the surface resistance value of the measured object.

1. When the battery voltage is lower than 5 volts, the LWBATTERY indicator will flash;
2. With digital display of temperature and humidity;
3. A multi-functional measuring instrument for measuring ambient temperature, humidity, and surface resistance.



Specification:

Surface resistance tester	BK699A
Operating Voltage	DC9V
Battery Life	40 hours (continuous work)
Display accuracy	1/2±1%
Size	100(L)x40(W)x170(H)mm
Measuring range	103Ω-1012Ω
Instrument weight	350g
Hammer weight	2.5±0.2kg/piece
Measure temperature	0°C-100°C
Measure humidity	0-100%RH

BK498

Electrostatic tester

The BK498 electrostatic wrist strap tester can quickly and easily check the following items for the electrostatic wrist strap:

1. The connection between the electrostatic wrist strap and the grounding wire;
2. The contact impedance between the electrostatic wrist strap and the skin;
3. Connection with grounding tools such as electrostatic connection plates, mats, etc.; to ensure the personal safety of staff;
4. Eliminate the possibility of product damage due to static electricity.



Specification:

Electrostatic tester	BK498
Power supply	9V dry battery
Ground wire	2.5m
Packing box size	1/2±1%
Size	115(W)x120(H)x47(D)mm
Weight	0.46kg

Test result:

Test impedance	LED indicator	Buzzer
$R < 800K\Omega$	Red light (LOW/low)	No sound
$800K\Omega \leq R \leq 9M\Omega$	Green light (GOOD/good)	Ring
$R > 9M\Omega$	Red light (HIGH/High)	No sound

BK485

Surface resistance tester

The surface resistance tester is an instrument for testing the surface resistivity and ground resistance of objects. It can perform simple and repeatable measurements of electrical conductivity, static dissipation, and insulating surface properties.

1. Using precision, low-power operational amplifier, accurate calculation, LCD module display;
2. High sensitivity and easy to use;
3. Small size, light weight, low power consumption;
4. Portable design, easy to carry.



Specification:

Surface resistance tester	BK485
Temperature range	In use ----5~49°C In storage ----15~60°C
Relative humidity	65RH%
Parsing	A series of quantities
Switching point	1/2 decimal on logarithm (3.16x10n)
Conversion point accuracy	±1/2 decimal
Accuracy	±5%
Repeatability	±5%

BK500/BK500B

Magnifier

1. High-quality magnifying glass work light, will not be hot after long time use, it is most suitable for precision electronics industry. The spring bracket can be fixed at any point according to your needs for the working environment. Please stay away from strong light to avoid accidents.

2. Fluorescent lights are three primary colors, the light does not flicker, can protect eyesight, the dual combination of magnification and lighting, make the observation clearer and more subtle, and the magnification can be selected according to different requirements. The structure design of desktop and bending poles; make Users can adjust the observation angle and position in a wide range according to their needs. (Note: After adjusting the support upper rod, support lower rod and support hook, please ensure that the lamp is stable. To meet the needs of the user.)



BK500 magnifying glass

Specification:

Magnifier	BK500
Gain	3X, 5X, 8X, 10X, 15X
Lens material	Glass-with ordinary lenses (blue glass)
	Optical lens (white glass)
	Optical master film (double large film 5X small film 10X)
Light source	22W circular fluorescent lamp
Lens diameter	127mm
Power supply	AC 220V, 110V (default 220V, 110V can be customized)
Plug	National standard three-pin plug (other standards can be customized)



BK500B magnifying glass

Specification:

Magnifier	BK500B
Gain	3X, 5X, 8X, 10X
Lens material	Glass-with ordinary lenses (blue glass)
	Optical lens (white glass)
	Optical master film (double large film 5X small film 10X)
Light source	22W circular fluorescent lamp
Lens diameter	127mm
Power supply	AC 220V, 110V (default 220V, 110V can be customized)
Plug	National standard three-pin plug (other standards can be customized)

Scope of application:

Electronic engineers observe and inspect minute components and component-intensive circuit boards, chemical engineering, printing and platemaking, stamp collecting, animal and plant specimen development, jewelry industry, students reading books, elderly newspapers or medical staff, beauticians, etc., which require lighting, Amplify the work.

BK500C/BK500D

Magnifier

1.High-quality magnifying glass work light, will not be hot after long time use, it is most suitable for precision electronics industry. The spring bracket can be fixed at any point according to your needs for the working environment. Please stay away from strong light to avoid accidents.

2.Fluorescent lights are three primary colors, the light does not flicker, can protect eyesight, the dual combination of magnification and lighting, make the observation clearer and more subtle, and the magnification can be selected according to different requirements. The structure design of desktop and bending poles; make Users can adjust the observation angle and position in a wide range according to their needs. (Note: After adjusting the support upper rod, support lower rod and support hook, please ensure that the lamp is stable. To meet the needs of the user.)



BK500C magnifying glass

Specification:

Magnifier	BK500C
Gain	3x, 5X, 8x, 10X, 15X, 20X
Lens material	Glass one has ordinary lenses (green glass)
	Optical lens (white glass)
	Optical master film (double large film 5X small film 10X)
Light source	22W circular fluorescent lamp
Lens diameter	127mm
Power supply	AC 220V, 110V (default 220V, 110V can be customized)
Plug	National standard three-pin plug (other standards can be customized)



BK500D magnifying glass

Specification:

Magnifier	BK500D
Gain	3x, 5X, 8x, 10X, 15X, 20X
Lens material	Glass one has ordinary lenses (green glass)
	Square optical lens
	Optical master film (double large film 5X small film 10X)
Light source	2x7W circular fluorescent tube
Lens diameter	113*177mm
Power supply	AC 220V, 110V (default 220V, 110V can be customized)
Plug	National standard three-pin plug (other standards can be customized)

Scope of application:

Electronic engineers observe and inspect minute components and component-intensive circuit boards, chemical engineering, printing and platemaking, stamp collecting, animal and plant specimen development, jewelry industry, students reading books, elderly newspapers or medical staff, beauticians, etc., which require lighting, Amplify the work.

BK500EF/BK600 Magnifier

1.High-quality magnifying glass work light, will not be hot after long time use, it is most suitable for precision electronics industry. The spring bracket can be fixed at any point according to your needs for the working environment. Please stay away from strong light to avoid accidents.

2.Fluorescent lights are three primary colors, the light does not flicker, can protect eyesight, the dual combination of magnification and lighting, make the observation clearer and more subtle, and the magnification can be selected according to different requirements. The structure design of desktop and bending poles; make Users can adjust the observation angle and position in a wide range according to their needs. (Note: After adjusting the support upper rod, support lower rod and support hook, please ensure that the lamp is stable. To meet the needs of the user.)



BK500E/F magnifying glass

Specification:

Magnifier	BK500E/F
Gain	3X、5X、8X、10X
Lens material	Glass one has ordinary lenses (green glass)
	Optical lens (white glass) Optical master film (double large film 5X small film 10X)
Light source	22W circular fluorescent lamp
Lens diameter	127mm
Power supply	AC 220V, 110V (default 220V, 110V can be customized)
Plug	National standard three-pin plug
	(other standards can be customized)
Height of floor stand	70cm
Net weight	8Kg



BK600 magnifying glass

Specification:

Magnifier	BK600
Gain	Daughter 10X, Master 3X
Lens material	Glass master
Light source	12W circular fluorescent lamp
Lens diameter	Daughter chip 22mm, master chip 90mm
Power supply	AC 220V, 110V (default 220V, 110V can be customized)
Plug	National standard two-pin plug
	(other standards can be customized)

Scope of application:

Electronic engineers observe and inspect minute components and component-intensive circuit boards, chemical engineering, printing and platemaking, stamp collecting, animal and plant specimen development, jewelry industry, students reading books, elderly newspapers or medical staff, beauticians, etc., which require lighting, Amplify the work.

BK-5600

Static Eliminator

1. Small size, light weight, portable design, adjustable angle;
2. Stable ion balance;
3. Quickly neutralize static electricity;
4. Using leakage magnetic transformer, long life and short circuit prevention;
5. Large-scale ion wind area;
6. Built-in ion emitter cleaner, easy to clean;
7. The adjustable speed fan generates a wide range of ion airflow;
8. Safe and low power consumption.



Specification:

Static Eliminator	BK-5600
Maximum power consumption	25W
The output voltage	5.6KV AC
Ion balance	±10V
Air volume	≈2.4m³/min
Effective range	40cmx150cm
Ozone production	≤0.03PPM (15cm in front of the fan)
Fan noise	45dB
Operating environment temperature	0°C-40°C
Packing box size	290(L)x175(H)x220(W)mm
Weight	2.5kg

In addition to static test results:

Operating voltage: AC220V, test voltage: 1KV-100V, ambient temperature: 25°C

Test distance (CM)	30	60	90	120
Static elimination time (S)	0.8	1.2	3.5	6.3
Ion balance (V)	0±10	0±7	0±5	0±2

※Remarks: The test data is 30cm away from the front panel, and the test result will vary depending on the ambient air temperature and humidity during the test will vary.

BK-5700-W

Horizontal ion fan

Ion fans have a wide range of uses. Ion fans are mainly used in the processing and assembly of electronic products, cameras, watches and other precision instruments, as well as the cutting, coiling and laminating of assembled plastic films, and the demolding of mold products.

1. Large-scale ion wind area, and the wind speed and air volume can be adjusted;
2. The blowing angle can be adjusted up and down, and there are desktop, desktop with arm clamps and hanging type to choose from;
3. There is a special ion emission cleaner;
4. With cold air heating function and automatic over-temperature protection function.



Specification:

Static Eliminator	BK-5700-W
Maximum power consumption	35W(cold air)/320W(hot air)
The output voltage	5.6KV AC
Ion balance	Adjusted to within $\pm 10V$ when leaving the factory (30cm from the panel)
Air volume	$\approx 3.3m^3/min$
Effective range	90cm*180cm
Ozone production	$\leq 0.03PPM$ (15cm in front of the fan)
Operating environment temperature	0°C-50°C
Packing box size	525(L)x270(H)x240(W)mm
Weight	6.4kg

In addition to static test results:

Operating voltage: AC220V, test voltage: 1KV-100V, ambient temperature: 25°C

Test distance (CM)	30	60	90	120
Static elimination time (S)	0.8	1.2	3.5	6.3
Ion balance (V)	0 \pm 10	0 \pm 7	0 \pm 5	0 \pm 3

※Remarks: The test data is 30cm away from the front panel, and the test result will vary depending on the ambient air temperature and humidity during the test will vary.

BK375/BK376

Automatic splitting/breaking tin machine

1. Reduce the flying and solder balls caused by lead-free solder during high temperature soldering.
2. The body is small and exquisite, saving working space.
3. It can improve the welding quality.



BK 375 Automatic splitting tin machine



BK 376 Automatic splitting tin machine

Specification:

Automatic breaking/cutting tin machine	BK375/BK376
Host power	DC24V/75mA
Motor power	DC24v/130mA
Delivery speed	27mm/s.
Solder diameter	Φ0.5, Φ0.6, Φ0.65, Φ0.8, Φ1.0
Dimensions	76(L) x 50(W) x 96(H)mm
Weight	590g
Power Adapter	DC24V

Test Conditions:

Set the temperature of the soldering iron to 350°C and 400°C respectively, add d1.0x500mm lead-free solder (Sn-3Ag-0.5Cu) to the soldering tip, and then measure the amount of flying flux. ※According to different test conditions, the amount of flux scattered will also be different.

BK201/202/203/204

lead-free round tin furnace

1. The welding area is small, which is suitable for tinning of wires and other wires;
2. The tin pot is made of imported pure titanium metal, which is resistant to high temperature and corrosion;
3. The control part is controlled by a microcomputer chip, and the temperature is accurate and fluctuates little;
4. With sleep function, it can prolong the service life of heating element and tin pot;
5. It has a fault prompt function, so that the operator can find the fault in time;
6. With key lock function to prevent the set temperature from being adjusted by mistake;
7. Adopt closed touch switch, easy to operate.



Specification:

Model	Rated power	Temperature range	Melting tin amount	Dimensions (mm)	Tin pot size (mm)
BK201	180W	0~600°C	0.3kg	266(L)x145(W)x120(H)	Φ38x40
BK202	250W	0~600°C	0.3kg	266(L)x145(W)x120(H)	Φ50x40
BK203	400W	0~600°C	0.3kg	327(L)x175(W)x120(H)	Φ80x40
BK204	500W	0~600°C	0.3kg	327(L)x175(W)x120(H)	Φ100x40

BK946A+

Preheating station

1. Adopt advanced quartz infrared heating element to heat fast and high efficiency,
2. Special IC can accurately control the temperature range, which can be set between 100 degrees and 380 degrees;
3. Built-in temperature sensor, temperature measurement and actual temperature digital tube display;
4. It can be used for preheating of circuit boards and other processes that require uniform heating of the whole;
5. Anti-static design.



Application range:

1. Any electronic industry sealing, dispensing and constant humidity heating;
2. Welding and maintenance of aluminum substrates in the LED industry;
3. Preheating of mold core in mold factory;
4. BGA repair solder ball, especially suitable for the desoldering work of large-size BGA;
5. Baking, drying and other temperature tests of samples heated at a constant temperature in various industries are essential tools for biology, genetics, medicine and health, environmental protection, biochemical laboratories, analysis rooms, and teaching and research.

Specification:

Preheating station	BK946A+
Scope of application	Circuit board preheating and desoldering
Temperature range	50°C ~350°C
Use environment temperature	0-40°C
Input voltage	AC220V
Temperature stability	±1°C
Maximum power	450W
Dimensions	L200xw200xH145mm
Net weight	5.03Kg

BK854

Preheating station

1. Adopt advanced quartz infrared heating element to heat fast and high efficiency,
2. Special IC can accurately control the temperature range, which can be set between 100 degrees and 380 degrees;
3. Built-in temperature sensor, temperature measurement and actual temperature digital tube display;
4. It can be used for preheating of circuit boards and other processes that require uniform heating of the whole;
5. Anti-static design.



Specification:

Preheating station	BK854
Scope of application	Circuit board preheating and desoldering
Temperature range	50°C ~350°C
Use environment temperature	0-40°C
Input voltage	AC220V
Temperature stability	±1°C
Maximum power	450W
Dimensions	L270xw230xH120mm
Net weight	2.63Kg

Z-CUT2

Tape Dispenser

1. Adjustable cutting length.
2. Superior performance in cutting narrow and soft tape.
3. Easy to set up and take out tape.
4. Compatible with tapes with inner diameter of: 75, 32, 25.
5. Available for both 220V and 110V models.



Suitable for

1. All gaps between the cutting of tapes are adjustable.
2. Used for all kinds of tapes and core holders.

Specification:

Model	Z-CUT 2
VOLTAGE	AC220V 50Hz/AC110V 60Hz
Power Consumption	14W
Tape width	3-22mm
Cutting Length	11-58±1mm
Roll Dia.	25/32/75mm
Weight	2.85Kg
Size	310(L)*170(W)*165(H)mm

Z-CUT9

Tape Dispenser

1. All sized tape can set up by pressing into the groove.
2. Tape length range: 5-999.
3. Preset up to 6 different length sizes.
4. Counting and rotating function.
5. Easy to set up and take out tape.
6. Compact and safe design.
7. Can insert double tape same time.
8. Dual Photo sensor.
9. Compatible with adhesive and non-adhesive tape, including packaging tapes, glass cloth, double-sided, filament tapes, acetate, masking, protective film, aluminum foil, craft and a large variety of others.



Specification:

Model	Z-CUT 9
Voltage	AC220V 50Hz/AC110V 60Hz
Power Consumption	14W
Tape width	6-60mm
Cutting Length	5-999±1mm, 200mm/s
Roll Dia.	300mm max
Weight	2.5Kg
Size	213(L)*140(W)*116(H)mm
Carton Size/Weight	270*170*240mm/3kgs

Z-CUT10

Tape Dispenser

- 1.Cuts tape and places it on carousel by pressing button.
- 2.It increases the production volume and brings efficient manufacturing.
- 3.Providing consistent clean lengths tape cutting.
- 4.Compatible with all sizes of tapes and accepting filament, polyimide, acetate cloth, glass cloth, double-sided tape, plastic, aluminum foil, cellophane, masking, normex, copper, cloth, polyethylene, PTFE, paper, craft, OPP, Kapton etc.
- 5.Adjustable length of the tape and gap of the tape by handle operation.
- 6.Easy to replace blades.
- 7.Motion sensor cutting. Infrared cutting



Specification:

Model	Z-CUT 10
Voltage	AC220V 50Hz/AC110V 60Hz
Electromechanical material	ABS
Tape width	3-25mm
Cutting Length	8-70mm
Roll Dia.	150mm max
Weight	1.9Kg
Size	256(L)*150(W)*256(H)mm

M1000/M1000S

Automatic Tape Dispenser

1. The dispenses tapes automatically on the carousel in specific length fast and precisely
2. it accepts most tapes and is perfect for packing, cell manufacturing and assembly work.



Specification:

Model	M1000/M1000S
Voltage	AC220V 50Hz/AC110V 60Hz
Power Consumption	18W
Tape width	7-50mm
Cutting Length	20-999mm±1mm/5-999mm
Roll Dia	N/A
Dimensions	L137xW245xH150mm
Net weight	2.4kg

BK180S/BK300S

Intelligent temperature control

1. Intelligent welding control system is a new type of welding station control mode that combines welding station, welding process information processing, and welding robot system. Very suitable for automated welding needs.
2. The welding station adopts an advanced 32-bit ARM4 microprocessor for work management and control. The control terminal can summarize, analyze, summarize, and notify abnormalities of the welding robot's working condition information.
3. The soldering station can estimate the remaining service life of the heating core and soldering iron tip consumables, and warn in advance when the service life of the soldering components is about to reach.



BK180H/S

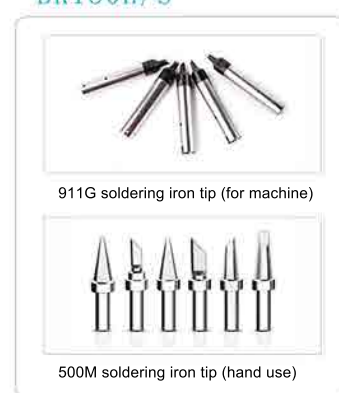

911G soldering iron tip (for machine)

500M soldering iron tip (hand use)

BK300H/S



501M soldering iron tip (hand use)

Function display:

High frequency and high power

Fast temperature rise, rapid temperature recovery, meeting high-speed welding and large spot welding

POST

Active self-test, grounding, leakage detection, heating core detection

Temperature warning

If the upper and lower limits of the set temperature are exceeded, the machine will automatically warn the user

Process storage

Different welding processes are set for different products, up to 100 groups of processes can be switched

Consumable life analysis

Set the working life time, and warn the working status of the heating core and the soldering iron tip

Robot communication

MODBUS-RTU protocol and standard data format to realize interaction with robots

Large screen display

Break through the tradition, large LCD color screen, data and function display more intuitive

Multi-language version

The interface has built-in Chinese and English languages, which can be used in a multi-regional working environment

Features

1. Using 280W electromagnetic heating core, full power output; perfect self-check and automatic protection function;
2. Abundant I/O control interface, suitable for automatic welding application welding process information processing, automatic adjustment of welding parameters; multiple alarm prompts;
3. The alarm signal light can be controlled externally;
4. Life warning function of welding parts;
5. Welding temperature curve display; Chinese/English menu switching;
5. Fahrenheit/Celsius temperature switch;
6. High temperature stability and rapid temperature recovery;
7. Normal working/abnormal signal output;
8. Welding process parameter information editing function;
9. Automatic alarm and protection if the temperature in the soldering station is too high;

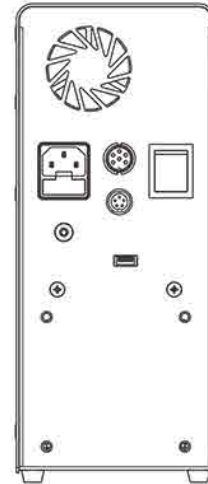

Technical parameters:

Product name	BK180S/BK300S
Applicable ambient temperature	-10~45°C
Applicable environmental humidity	45~80%RH
Rated voltage	AC230V
Rated fuse	AC250V 3A/5A (slow break)
Host rated power	180W/300W
Maximum output capacity	AC24V ±1V
Rated handle power	150W/280W
Temperature control range	100~480°C/212~896°F
Temperature stability	+2°C (static)
Temperature correction range	+50°C/+90°F
Ground resistance/leakage voltage	4Ω/2mV
I/O allowable voltage	DC24V (PLC control voltage)
I/O allowable current	10mA-3mA (PLC control current)
Shape volume	116(L)X126(W)x272(H)mm

Interface definition:

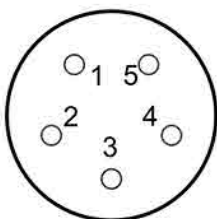

1	PLC 24V
2	Sleep input
3	Alarm Output
4	Temperature OK output
5	PLC GND

Wiring definition of signal output port:

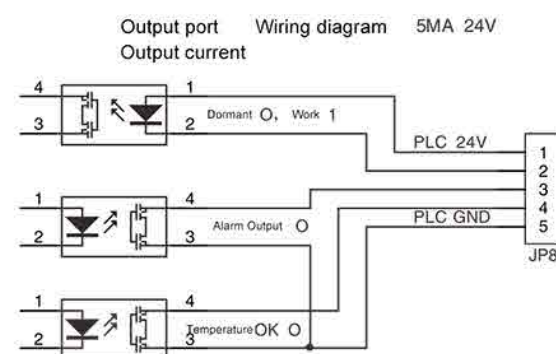

BK2200

Intelligent and efficient temperature control

1. The large-screen LCD display is beautiful and generous;
2. High frequency eddy current heating efficiency and high welding sensitivity;
3. High temperature control accuracy and rapid temperature recovery;
4. Three-level quick temperature adjustment, one key to the preset temperature;
5. It has a sleep function to prevent oxidation of the soldering iron tip;
6. Remote IO control and working status reading;
7. The internal use of switching power supply, high energy efficiency ratio, can adapt to 110V/220V wide voltage



Specification:

Intelligent and efficient temperature control	BK2200
Operating Voltage	AC100-240V,50Hz/60Hz
Temperature range	100°C ~480°C
Host rated power	200W
Temperature stability (no load)	±2°C
Resistance of soldering iron tip to ground	≤2Ω
Temperature compensation range	<2mV
Temperature control range	±50°C/±90°F
Out of tin length	0.3-200mm
I/O allowable voltage	DC24V (PLC (control voltage)
I/O allowable current	10mA-3mA (PLC control current)
Use environment	Temperature: -10~45°C; Humidity: 45~80%RH
Shape volume	108 (L) x116 (w) · x197 (H) mm

Accessories:



LF301G handle



VH300 heating core



911G Soldering iron stand

BK2300

Intelligent and efficient temperature control

1. The large-screen LCD display is beautiful and generous;
2. High frequency eddy current heating efficiency and high welding sensitivity;
3. High temperature control accuracy and rapid temperature recovery;
4. Three-level quick temperature adjustment, one key to the preset temperature;
5. It has a sleep function to prevent oxidation of the soldering iron tip;
6. Remote IO control and working status reading;



Specification:

Intelligent and efficient temperature control	BK2300
Operating Voltage	AC100-240V,50Hz/60Hz
Temperature range	100°C ~480°C
Host rated power	300W
Temperature stability (no load)	±2°C
Resistance of soldering iron tip to ground	≤2Ω
Temperature compensation range	<2mV
Temperature control range	±50°C/±90°F
I/O allowable voltage	DC24V (PLC (control voltage)
I/O allowable current	10mA-3mA (PLC control current)
Use environment	Temperature: -10~45°C; Humidity: 45~80%RH
Shape volume	108 (L) x116 (w) x197 (H) mm

Accessories:



LF308C Handle



VH500S heating core



501M Soldering iron stand

Technology , innovation , win the future

Contact us

Shenzhen Bakon Electronic Technology Co., Ltd.

Telephone: 400-0988-936

Office: 9th Floor, Ruihui Building, Gongming Street, Guangming New District, Shenzhen

Factory1: Floor 3-5, Building A, Fubulun Industrial Zone, Chaoyang Road, Yanchuan, Songgang Street, Baoan District, Shenzhen

Factory2: Golden Building, Jinrong Ruifu Industrial Park, West of North Section of Jiefang Road, Xuedian Town, Xinzheng City, Zhengzhou City, Henan Province