

# NT-500 SERIES

## Weighing Indicator

- Tare value input by numeric keys
- 6 wire and 4 wire load cell support
- Weight back-up function
- Hold functions(average/peak/sampling)
- 50 set points & product ID codes input



# NT-500 SERIES Weighing Indicator

## FEATURES

- Tare value input by numeric keys
- 6 wire and 4 wire load cell support
- Digital noise filter
- RFI/EMI screened
- Watch-dog function
- Weight back-up function
- Hold functions (average/peak/sampling)
- 50 set points & product ID codes input
- RS-232C serial port & real time clock included
- PC command mode
- Relay input : 4 points
- Relay output : 4 points (NT-502A/NT-505A)
- Application : Platform scale, Truckscale,  
Packer/Hopper scale  
Tension/Compression Tester

## SPECIFICATIONS

Model	NT-501A	NT-502A	NT-505A
Input Sensitivity	Over 0.6 $\mu$ V/D		
Load cell Excitation Voltage	DC 9V (up to 8EX)		
A/D Internal Resolution	1/200,000		
A/D External Resolution	1/10,000 (Max.)		
A/D Conversion Rate	50 times/sec (Max.)		
A/D Conversion Type	Sigma-Delta Method		
Display	7 digit (F.I.P)		
Power Source	AC 110V/220V ( $\pm$ 10%)		
Dimension (mm)	185.5(W) $\times$ 168.5(D) $\times$ 92.5(H)		
Panel Cutting Size	186.5(W) $\times$ 93.5(H) mm		
Product Weight	2.4 kg		

## OPTIONS

- RS-485/422
- Analog output: I-out (4~20mA)
- Analog output: V-out (0 ~ 10V)
- BCD out

## DIMENSIONS

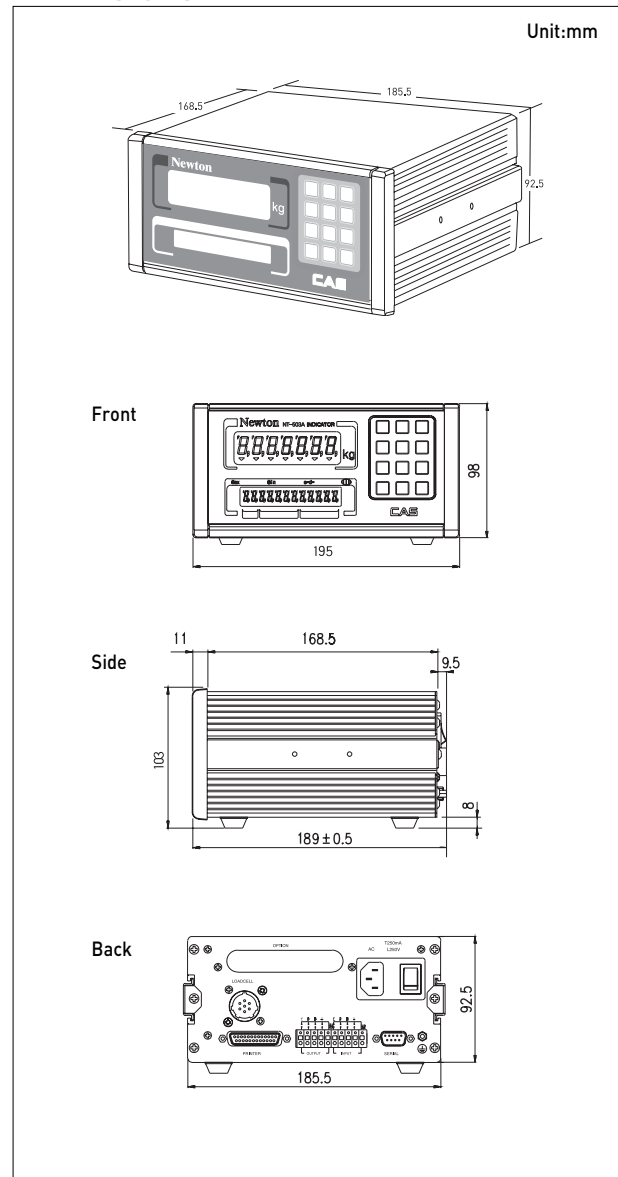

# CAS

CAS BLDG., # 440-1, SUNGNAE DONG,  
GANGDONG GU, SEOUL, KOREA  
TEL\_ 82 2 2225 3500  
FAX\_ 82 2 475 4668  
<http://www.globalcas.com>

Specifications are subject to change for improvement without prior notice.