

sanwa®



CD732

デジタルマルチメータ
DIGITAL MULTIMETER

取扱説明書
INSTRUCTION MANUAL



CONTENTS

[1]	SAFETY PRECAUTIONS:Before use, read the following safety precautions	
1-1	Explanation of Warning Symbols	32
1-2	Warning Instruction for safe use.....	32
1-3	Maximum Overload Protection Input	33
[2]	APPLICATION AND FEATURES	
2-1	Application	34
2-2	Features	34
[3]	NAME OF COMPONENT UNITS	
3-1	Display	34
3-2	Multimeter, Test leads	35
[4]	Description of Functions	
4-1	Switches/buttons and description	36
4-2	How to Use the Stand	37
[5]	MEASUREMENT PROCEDURE	
5-1	Start-up Inspection	38
5-2	DC voltage measurement (DCV).....	39
5-3	AC voltage measurement (ACV)	40
5-4	Line frequency measurement (Hz)	41
5-5	Duty ratio measurement (Duty)	42
5-6	Resistance measurement (Ω)	43
5-7	Diode test (\rightarrow)	44
5-8	Circuit continuity check (\rightarrow)	45
5-9	Capacitor measurement (\rightarrow)	46
5-10	Current Measurement (μ A, mA, A)	47
5-10-1	DC/AC current (DC/AC μ A, DC/AC mA)	47
5-10-2	DC/AC current (DC/AC A)	48
5-11	How to use optional products	50
5-11-1	Measurement using the AC flexible clamp sensor (CL3000)	50
5-11-2	Measurement using the DC/AC current probe (CL-22AD)	51
5-11-3	Measurement using the DC current probe (CL33DC)	52
5-11-4	Measurement using the DC high-voltage probe (HV-60)	53
[6]	MAINTENANCE	
6-1	Maintenance and inspection	54
6-2	Calibration	54
6-3	How to Replace Battery and Fuse	54
6-4	Cleaning and Storage	56
[7]	SPECIFICATIONS	
7-1	Measurement Range and Accuracy	57
7-2	General Specifications	59
7-3	Optional accessories	60
[8]	After-Sales Service	
8-1	Warranty and Provision.....	61
8-2	Repair	61
8-3	SANWA web site	61

[1] SAFETY PRECAUTIONS : Before use, read the following safety precautions

This instruction manual explains how to use your multimeter CD732 safely. Before use, please read this manual thoroughly. After reading it, keep it together with the product for reference to it when necessary.

Using this product in ways not specified in this manual may damage its protection function.

The instruction given under the heading "⚠ WARNING" "⚠ CAUTION" must be followed to prevent accidental burn or electrical shock.

1-1 Explanation of Warning Symbols

The meaning of the symbols used in this manual and attached to the product is as follows.

⚠ : Very important instruction for safe use.

- The warning messages are intended to prevent accidents to operating personnel such as burn and electrical shock.
- The caution messages are intended to prevent damage to the instrument.

⚡ : Dangerous voltage (Take care not to get an electric shock involtage measurement.)

— : DC

~ : AC

Ω : Resistance

••••• : Buzzer

→| : Diode

Hz: Line frequency

Duty: Duty ratio

⊥ : Capacitor

+ : Plus

- : Minus

□ : Double insulation

⊞ : Fuse

⊥ : Ground

1-2 Warning Instruction for safe use

⚠ WARNING

To ensure that the meter is used safely, Be sure to observe the instruction when using the instrument.







1. Never use meter on the electric circuit that exceed 6 kVA.
2. Pay special attention when measuring the voltage of AC 33 Vrms (46.7 Vpeak) or DC 70 V or more to avoid injury.
3. Never apply an input signals exceeding the maximum rating input value.
4. Never use meter for measuring the line connected with equipment (i.e. motors) that generates induced or surge voltage since it may exceed the maximum allowable voltage.

5. Never use meter if the meter or test leads are damaged or broken.
6. Never use uncased meter.
7. Be sure to use a fuse of the specified rating or type. Never use a substitute of the fuse or never make a short circuit of the fuse.
8. Always keep your fingers behind the finger guards on the probe when making measurements.
9. Be sure to disconnect the test pins from the circuit when changing the function or range.
10. Never use meter with wet hands or in a damp environment.
11. Never open tester case except when replacing batteries or fuse. Do not attempt any alteration of original specifications.
12. To ensure safety and maintain accuracy, calibrate and check the tester at least once a year.
13. Indoor use.

⚠ CAUTION

1. Correct measurement may not be performed when using the meter in the ferromagnetic / intense electric field such as places near a transformer, a high-current circuit, and a radio.
2. The meter may malfunction or correct measurement may not be performed when measuring special waveform such as that of the inverter circuit.

1-3 Maximum Overload Protection Input

Function	Input	Maximum rating input value	Maximum overload protection value
DCV	V, Hz,	DC 1000 V	DC 1000 V, AC 750 V or peak max. 1000 V
ACV/Hz/Duty	Duty, Ω,	AC 750 V	
Ω /  /  /  / 	 ,  , μA, mA (+) and COM (-)	⚠ Voltage and current input prohibited	
DC/AC 600 • 6000 μA DC/AC 60 • 600 mA		DC/AC 600 mA, ⚠ Voltage input prohibited.	0.4 A/1000 V fuse* Breaking capacity 30 kA
DC/AC 6•15 A	6•15 A (+) and COM (-)	DC/AC 15 A, ⚠ Voltage input prohibited.	16 A/1000 V fuse Breaking capacity 30 kA

* According to the time-current characteristic curve of the 0.4 A fuse, it will never blow at 0.6 A but blows in less than 0.1 sec. when the current exceeds 1.5 A. This characteristic is completely suitable for use with this instrument.

[2] APPLICATION AND FEATURES

2-1 Application

This instrument is a portable digital multimeter desired for measurements of weak, low-capacity electrical circuitry. It is not only a powerful tool for measuring small communications equipment, home appliances, lamp line circuits and batteries but can also be used in circuit analyses by using the additional functions.

2-2 Features

- Safe design compliant to international safety standards including EN61010-1 CAT. III DC/AC 600 V and CAT. II DC 1000 V/AC 750V (CE marked product).
- 6000-count full scale (4000-count with $\overleftarrow{\leftarrow}$) display, and bar graphs (except for Hz, Duty, $\overleftarrow{\leftarrow}$ and $\overrightarrow{\rightarrow}$).
- Data hold and range hold functions.
- Auto power save activated in about 16 min.
- Capacitor measurement function for a wide range of capacitance (0.01 nF to 3999 μ F).
- Holster for holding the test lead or hanging it from the wall.
- 6 \cdot 15 A measurement terminal provided with a safety cover for preventing erroneous insertion.
- Main unit case and the circuit boards are made of fire-retarding materials.
- Circuit continuity check possible by a buzzer beep and the red LED lighting.

[3] NAME OF COMPONENT UNITS

3-1 Display

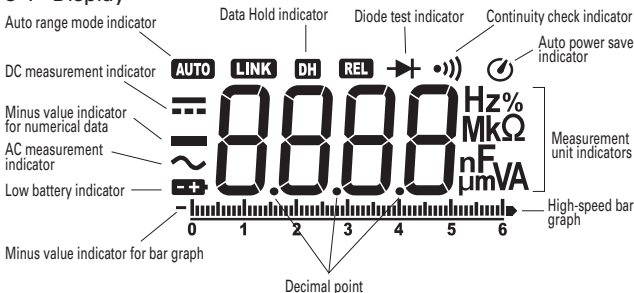

[4] Description of Functions

4-1 Switches/buttons and description

○ Power switch and function switch

Turn this switch to turn on and off the power and to select the functions of V, Ω , \rightarrow , \bullet , \leftarrow , μ A, mA, A.

○ Range hold button

Pressing this button once sets the manual mode and the range is fixed. ("AUTO" on the display disappears)

Once the manual mode is set, the range moves each time this button is pressed. Checking the unit on the display and the place of the decimal point, select a desired range. To return to the auto mode, keep pressing this button until "AUTO" on the display appears.

○ Data hold button

When this button is pressed, the data display at that time continues ("DH" lights on the display). When the measuring input changes, the display will not change.

When this button is pressed again, the hold status is canceled you can return to the measuring status. ("DH" on the display disappears.)

○ Select button

When this button is pressed (\rightarrow), the each modes change as follows.

ACV / Hz / Duty	ACV \rightarrow Hz \rightarrow Duty \rightarrow ACV
Ω / \rightarrow / \bullet / \leftarrow	Ω \rightarrow \rightarrow \rightarrow \bullet \rightarrow \leftarrow \rightarrow Ω
600 · 6000 μ A	
60 · 600 mA	DCA \rightarrow ACA \rightarrow DCA
6 · 15 A	

- When the function switch is switched, the range switches to the auto range of the mode specified on the left end.

WARNING

Do not change over the function switch with a voltage applied to the measuring terminals.

○ Auto power save

This instrument incorporates the auto power save function that turns off the display in about 16 minutes to save the battery draining. When the rotary switch or a switch button is not controlled while this instrument is ON, the warning buzzer beeps in about 15 minutes and then the instrument power and display are turned off automatically in 1 minute after. Every time a switch button is pressed or the function switch is switched during measurement, the time until the auto power save function is activated is extended by about 16 minutes.

To recover from the auto power save mode where the display is off, press one of the three switch buttons.

This function can be disabled by holding the SELECT button while turning the function switch to switch the power ON.

When this function is disabled, the  indicator on the display is extinguished.

As a small amount of the battery power drains even when the instrument is turned OFF by the auto power save function, be sure to set the rotary switch to OFF when not using the instrument.

○ OVER LOAD (O.L) indication

In case of excess input to this device, the indicator displays O.L. If O.L is displayed during the voltage function, stop the input immediately. When a DC 1000 V or higher voltage is input while the DCV function is selected or when an AC 750 V or higher voltage is input while the ACV, Hz or Duty function is selected, the instrument generates warning with intermittent buzzer beeps and the flashing LED.

4-2 How to Use the Stand

Please use the stand that there is on the side of rear case like a figure.

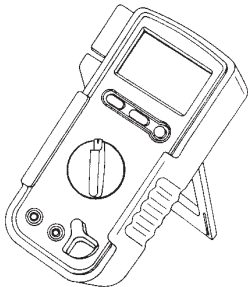

[5] MEASUREMENT PROCEDURE

5-1 Start-up Inspection

⚠ WARNING

1. Never use meter if the meter or test leads are damaged or broken.
2. Make sure that the test leads are not cut or otherwise damaged.

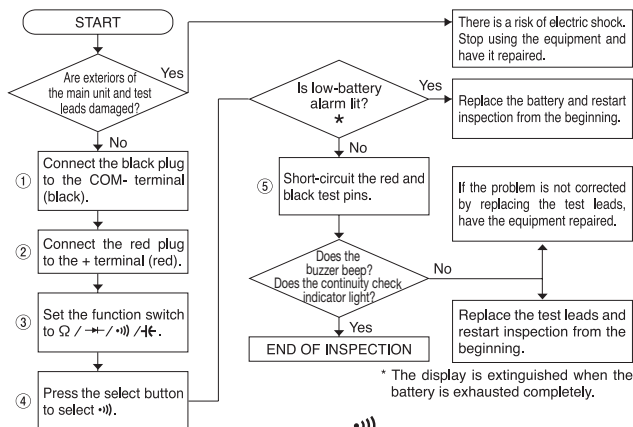

* The display is extinguished when the battery is exhausted completely.

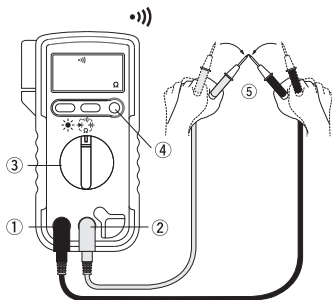

5-2 DC voltage measurement (DCV)

⚠ WARNING

1. Never apply a voltage signal exceeding the maximum rated input value.
2. Do not turn the rotary switch to change the function during measurement.
3. Always keep your fingers behind the finger guards on the test lead when making a measurement.

Function	Maximum rated input	Ranges
DCV ---	DC 1000 V	600.0 mV, 6.000 V, 60.00 V, 600.0 V, 1000 V

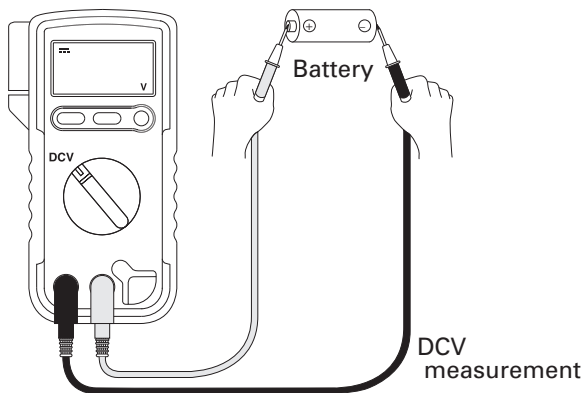

Note:

- The displayed value fluctuates when the test leads are open, but this is not malfunction. Particularly, with the 600.0 mV range, the high input impedance may cause the display to fluctuate or show "O.L" when the test leads are open.
- Malfunction may occur if the voltage measurement of the horizontal oscillation output circuitry of a TV is attempted.

5-3 AC voltage measurement (ACV)

⚠ WARNING

1. Never apply a voltage signal exceeding the maximum rated input value.
2. Do not turn the rotary switch to change the function during measurement.
3. Always keep your fingers behind the finger guards on the test lead when making a measurement.

Function	Maximum rated input	Ranges
ACV ~	AC 750 V	6.000 V, 60.00 V, 600.0 V, 750 V

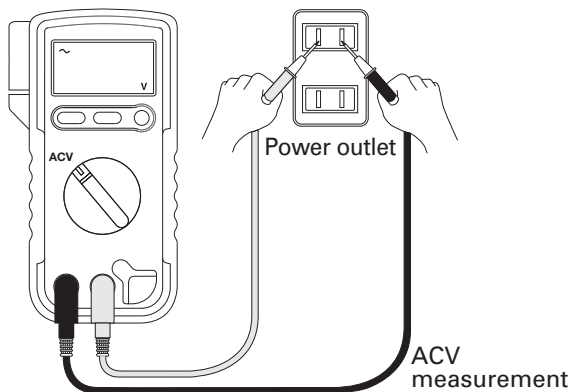

Note:

- With the AC 6.000 V range, a few counts of numeric may remain when the input is 0 (shorted).
- As this instrument employs the mean value method for the AC detection, measurements become erroneous when the input waveform is other than a sine wave (the frequency range is 45 to 500 Hz).

5-4 Line frequency measurement (Hz)

⚠ WARNING

1. Never apply a voltage signal exceeding the maximum rated input value.
2. Do not turn the rotary switch to change the function during measurement.
3. Always keep your fingers behind the finger guards on the test lead when making a measurement.

Function	Maximum rated input	Ranges
Hz	99.99 kHz (≤ 100 Vrms)	9.999 Hz, 99.99 Hz, 999.9 Hz, 9.999 kHz, 99.99 kHz (Auto range only)

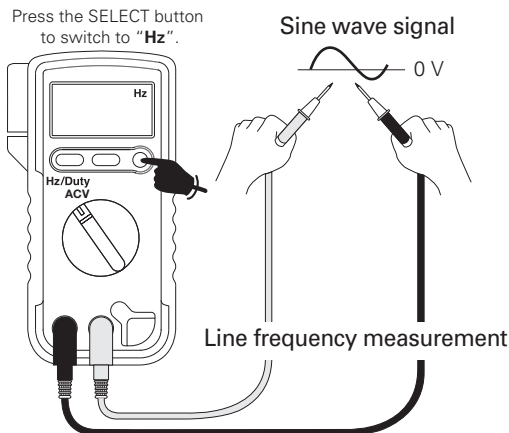

Note:

- The frequency measurement range is from 5 Hz to 99.99 kHz. The input signal condition is: Sine wave (zero-cross sin signal waveform) from 5 to 100 Vrms.
- If the measured frequency contains noise, the measurement values may become unstable.
- The bar graph is not displayed with the frequency measurement. The measurement is possible only with the auto range.

5-5 Duty ratio measurement (Duty)

⚠ WARNING

1. Never apply a voltage signal exceeding the maximum rated input value.
2. Do not turn the rotary switch to change the function during measurement.
3. Always keep your fingers behind the finger guards on the test lead when making a measurement.

Function	Maximum rated input	Ranges
Duty	1 kHz (≤ 60 Vp-p)	20.0 to 80.0% (Auto range only)

Press the SELECT button to switch to "Duty".

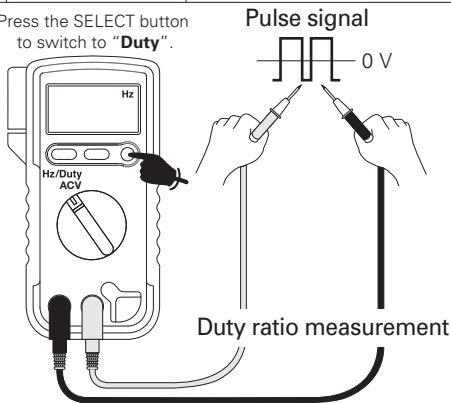

Note:

- The duty ratio measurement range is from 20 % to 80.0 %.
The input signal condition is: Zero-cross pulse signal of 5 Hz to 1 kHz, 5 Vp-p to 60 Vp-p.
The zero-cross pulse refers to a pulse-waveform signal changing the polarity in order of (+ potential → - potential → + potential). This instrument cannot measure a signal composed of the + potential alone, such as the logic pulse, or the - potential alone.
- If the measured frequency contains noise, the measurement values may become unstable.
- The bar graph is not displayed with the duty ratio measurement.
The measurement is possible only with the auto range.

5-6 Resistance measurement (Ω)

WARNING

Never apply an external voltage or current to the measurement terminals.

Function	Maximum rated input	Ranges
Ω	60.00 M Ω	600.0 Ω , 6.00 k Ω , 60.00 k Ω , 600.0 k Ω 6.000 M Ω , 60.00 M Ω

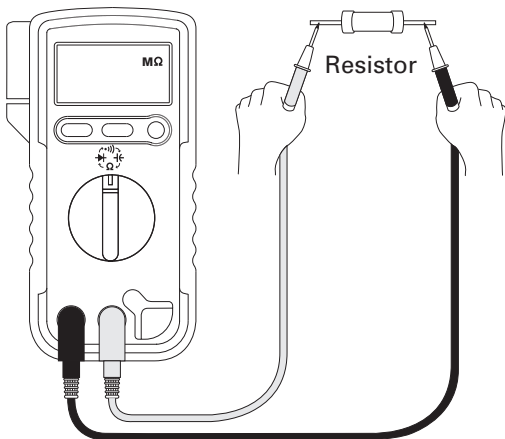

Note:

- The open voltage across the measurement terminals is about 0.63 V.
- If the measurement is affected by noise, shield the measurement subject with the potential of COM (–).
- If a test pin or the measurement subject is touched by a finger during measurement, a measurement error will result due to the resistance of the human body.

5-7 Diode test (→)

⚠ WARNING

Never apply an external voltage or current to the measurement terminals.

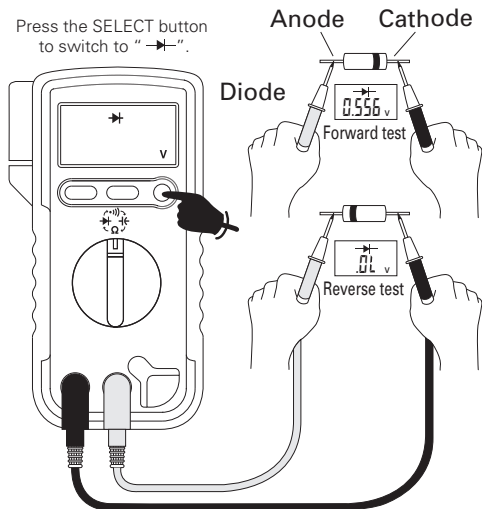

Note:

- The open voltage across the measurement terminals is about 2.7 V.
- If the forward voltage of the diode is equal to or more than the open voltage, "O.L" is displayed even in the forward test.

5-8 Circuit continuity check (•))

⚠ WARNING

Never apply an external voltage or current to the measurement terminals.

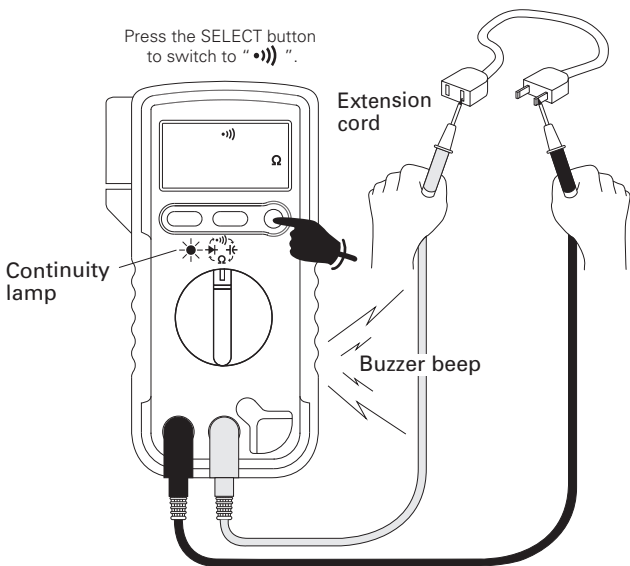

Note:

- The open voltage across the measurement terminals is about 0.63 V.
- The continuity buzzer beeps and the continuity lamp lights when the resistance is between 10 and 60 Ω .

5-9 Capacitor measurement (⚡)

⚠ WARNING

Never apply an external voltage or current to the measurement terminals.

⚠ CAUTION

1. Discharge the measurement target capacitor before the measurement.
2. As this instrument measures the capacitance by applying current to the capacitor, it is not suitable for measuring an electrolytic capacitor with high leak current because of an increased error.
3. The measurement time is extended in the measurement of a capacitor with large capacitance (about 30 sec. in a 4000 μF range).

Function	Maximum rated input	Ranges
Capacitor ⚡	4000 μF	40.00 nF, 400.0 nF, 4.000 μF , 40.00 μF , 400.0 μF , 4000 μF (Auto range only)

Press the SELECT button to switch to "⚡".

•1000 nF=1 μF

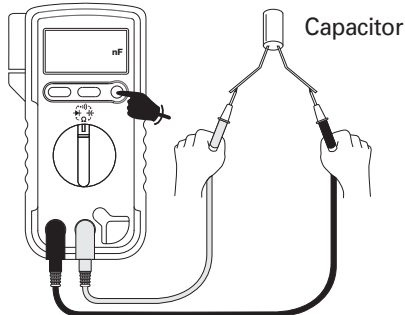

Note:

- The display may become unstable due to the flowing capacitance of ambient noise or the test leads. To minimize the effects of the floating capacitance, connect the measurement target (capacitor) directly to the + and COM (—) measurement terminals whenever possible.
- The bar graph is not displayed with the capacitor measurement. The measurement is possible only with the auto range.

5-10 Current Measurement (μA , mA, A)

⚠ WARNING

(Applicable to both sections 5-10-1 and 5-10-2)

1. Never apply voltage to the input terminals.

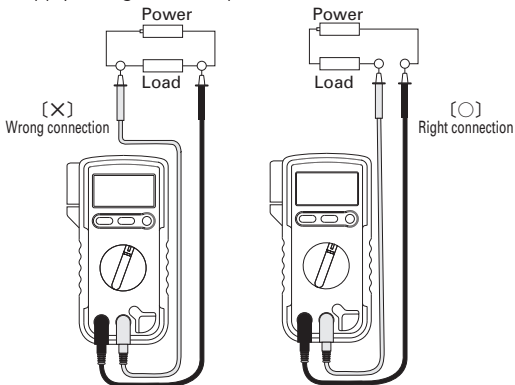

2. Be sure to make a series connection via load.
(please see to above drawing)
3. Do not apply an input exceeding the maximum rated current to the input terminals.

⚠ CAUTION

Check that the built-in fuses are not blown.

5-10-1 DC/AC current (DC/AC μA , DC/AC mA)

Function	Maximum rated input	Ranges
DC/AC μA	6000 μA	600.0 μA , 6000 μA
DC/AC mA	600.0 mA	60.00 mA, 600.0 mA

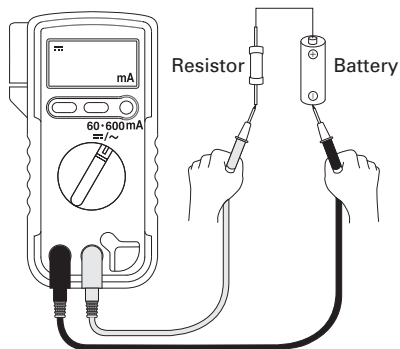

Example of DC 60-600 mA range measurement

Note:

- As this instrument employs the mean value method for the AC detection, measurements become erroneous when the input waveform is other than a sine wave (the frequency range is 45 to 500 Hz).
- The current measured with this method decreases by the amount that the internal resistance of the current range is inserted in series. The effect of this phenomenon is particularly noticeable when measuring the current of a low-resistance circuit. The resistance value of the μA range is about $50\ \Omega$ while that of the mA range is about $0.5\ \Omega$.
- If the displayed value hardly changes when the input signal is applied or becomes much lower than expected, the measurement terminals or function switch are set erroneously or the fuse ($\phi 6.3 \times 32$ mm size, $0.4\ \text{A}/1000\ \text{V}$) may be blown. Please check them.
- The $\mu\text{A}/\text{mA}$ switching is performed with the rotary switch.
- The DC/AC switching is performed with the SELECT button.

5-10-2 DC/AC current (DC/AC A)

⚠ WARNING

1. Never apply voltage to the input terminals.
2. The current measurement is accompanied with heat generation. When measuring current of 6 A or more, complete each measurement within 10 seconds and leave an interval of 5 minutes or more between measurements.
3. Perform measurement with the leads kept straight to prevent overheat.

Function	Maximum rated input	Ranges
DC/AC A	15 A	6.000 A, 15.00 A

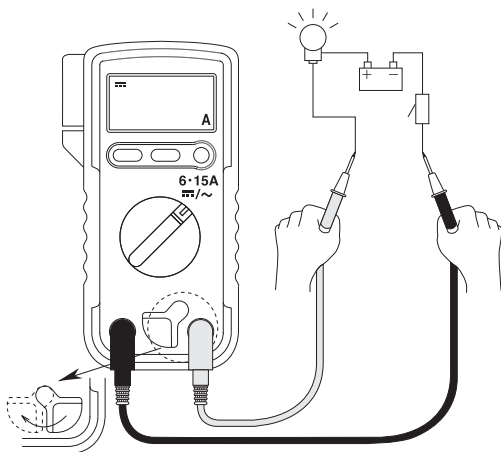

Example of DC 6-15 A range measurement

Note:

- As this instrument employs the mean value method for the AC detection, measurements become erroneous when the input waveform is other than a sine wave (the frequency range is 45 to 500 Hz).
- If the displayed value hardly changes when the input signal is applied or becomes much lower than expected, the measurement terminals or function switch are set erroneously or the fuse (ϕ 10 x 38 mm size, 16 A/1000 V) may be blown. Please check them.
- Continuous measurement is permissible for current below 6 A. (When measuring 6 A or higher current, complete each measurement within 10 seconds and leave an interval of 5 minutes or more between measurements.)
- In case of measurements taking a long period, use the optional clamp probe.
- The DC/AC switching is performed with the SELECT button.

5-11 How to use optional products

WARNING

Never apply an input signals exceeding the maximum rating input value of optional products.

5-11-1 Measurement using the AC flexible clamp sensor (CL3000) Maximum measurable current: AC 3000 A

1) Measurement target

AC sine wave of 50-60 Hz, such as the current consumption of a home appliance or power supply equipment.

2) Measurement ranges

Three ranges of AC 30 A, AC 300 A and AC 3000 A.

3) Measurement procedure

- ① Connect the red plug of the current probe to the + measurement terminal and the black plug to the COM (—) terminal.
 - ② Set the function switch of this instrument (CD732) to "ACV".
 - ③ Set the range hold button to the 6 V range.
 - ④ Set the range setting knob of the current probe to the 30 A, 300 A or 3000 A
 - ⑤ range.
 - ⑥ Clamp the measurement target conductor with the current probe.
- If the range of the current probe is 30 A, read the displayed value by multiplying it by 10. Similarly, multiply it by 100 with the 300 A range and multiply by 1000 with the 3000 A. The
- ⑦ unit of the obtained value is A (ampere).

After the measurement, disconnect the current probe from the

- ⑧ measurement target conductor.

Set the power switches of this instrument (CD732) and probe (CL3000) to OFF.

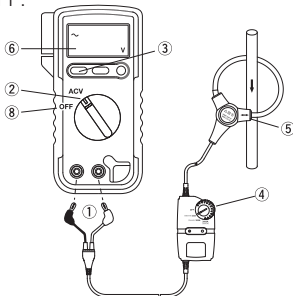

5-11-2 Measurement using the DC/AC current probe (CL-22AD) Maximum measurable current: DC/AC 200 A

1) Measurement target

ACA: Measurement of AC sine wave of 50-60 Hz, such as the current consumption of a home appliance or power supply equipment.

DCA: Measurement of the current drain of the electrical circuitry of an automobile or other DC devices.

2) Measurement ranges

Two for each of ACA and DCA (20 A and 200 A).

3) Measurement procedure

① Connect the red plug of the current probe to the + measurement terminal and the black plug to the COM (—) terminal.

② Set the function switch of this instrument (CD732) to "DCV" for DCA measurement or "ACV" for ACA measurement.

③ Set the range hold button to the DC 600 mV range for DCA measurement or the AC 6 V range for ACA measurement.

④ Set the range setting knob of the current probe to the 20 A or 200 A range.

* In the case of DCA measurement, turn the zero adjustment knob of the current probe so that this instrument (CD732) displays "000.0 mV".

⑤ Open the iron core of the current probe and clamp the measurement target conductor with it.

⑥ Read the displayed value by multiplying it as shown below.
The unit of the obtained value is A (ampere).

DC 20 A → 0.1x

AC 20 A → 100x

DC 200 A → 1x

AC 200 A → 1000x

⑦ After the measurement, open the iron core of the current probe and disconnect it from the measurement target conductor.

⑧ Set the power switches of this instrument (CD732) and probe (CL-22AD) to OFF.

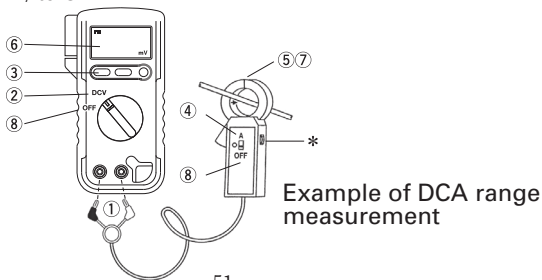

5-11-3 Measurement using the DC current probe (CL33DC) Maximum measurable current: DC 300 A

- 1) Measurement target
Current drain of the electrical circuitry of an automobile or other DC devices.
- 2) Measurement ranges
Two (30 A and 300 A).
- 3) Measurement procedure
 - ① Connect the red plug of the current probe to the + measurement terminal and the black plug to the COM (—) terminal.
 - ② Set the function switch of this instrument (CD732) to "DCV".
 - ③ Set the range hold button to the DC 600 mV range.
 - ④ Set the range setting knob of the current probe to the 30 A or 300 A range and turn the zero adjustment knob so that this instrument (CD732) displays "000.0 mV".
 - ⑤ Open the iron core of the current probe and clamp the measurement target conductor with it.
 - ⑥ If the range of the current probe is 30 A, read the displayed value by multiplying it by 0.1. If the range is 300 A, multiply it by 100. The unit of the obtained value is A (ampere).
 - ⑦ After the measurement, open the iron core of the current probe and disconnect it from the measurement target conductor.
 - ⑧ Set the power switches of this instrument (CD732) and probe (CL33DC) to OFF.

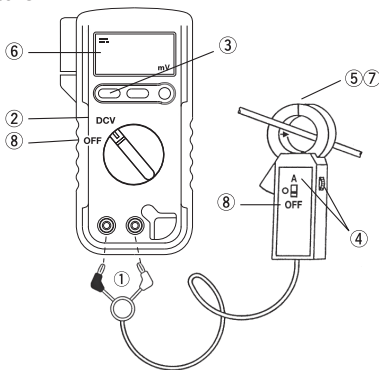

5-11-4 Measurement using the DC high-voltage probe (HV-60) Maximum measurable voltage: DC 30 kV

⚠ WARNING

1. The HV probe is designed to measure low-current circuitry. Do not use it to measure high voltages of power transmission line, etc.
2. Do not apply a voltage higher than the maximum measurable voltage (DC 30 kV) of the probe.
3. Do not change the function during measurement.
4. Do not turn the rotary switch to change the function during measurement.

- 1) Measurement target: Anode voltage of a cathode ray tube, voltage of high-impedance circuitry such as a high focusing voltage.
- 2) Measurement range: DC 1000 V.
- 3) Measurement procedure
 - ① Connect the red plug of the HV probe to the + measurement terminal and the black plug to the COM (—) terminal.
 - ② Set the function switch to "DCV" and the range hold button to the DC 1000 V range.
 - ③ Connect the black clip to the ground line of the measurement target and apply the pin on the tip of the HV probe to the measured point.
 - ④ Read the displayed value by multiplying it by 0.1. The unit of the obtained value is kV.
 - ⑤ After the measurement, remove the pin from the measurement target and then disconnect the clip.
- The HV-60 cannot be used for AC voltage measurements.

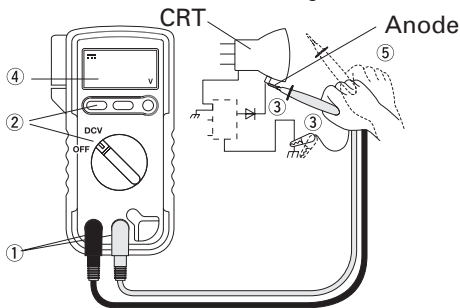

[6] MAINTENANCE

WARNING

1. This section is very important for safety. Read and understand the following instruction fully and maintain your instrument properly.
2. The instrument must be calibrated and inspected at least once a year to maintain the safety and accuracy.

6-1 Maintenance and inspection

1. Appearance

- Is the appearance not damaged by falling?

2. Test leads

- Is the cord of the test leads not damaged?
- Is the core wire not exposed at any place of the test leads?

If your instrument falls in any of the above items, do not use it and have it repaired or replace it with a new one.

- Make sure that the test leads are not cut, referring to the section.

6-2 Calibration

The calibration and inspection may be conducted by the dealer.
For more information, please contact the dealer.

6-3 How to Replace Battery and Fuse

WARNING

1. If the rear case is removed with input applied to the input terminals, you may get electrical shock. Before starting the work, always make ure that no inputs is applied.
2. Be sure to use the fuse is same rating so as to ensure safety and performance of tester.
3. When operator remove the rear case, do not touch the internal parts or wire with hand.

CAUTION

When replacing batteries, always replace both of them together.
(Do not mix new and used batteries.)

Factory -preinstalled built-in battery

A battery for monitoring is preinstalled before shipping, therefore it may run down sooner than the battery life specified in the instruction manual.

*The "battery for monitoring" is a battery to inspect the functions and specifications of the product.

<How to replace the battery>

- ① Remove the holster from the main unit.
- ② Open the stand on the rear of the main unit and remove the rear case retaining screw using a Phillips screwdriver.
- ③ Remove the rear case as if flapping it up from the bottom, and take out the exhausted batteries from the rear case.
- ④ Insert brand-new batteries by taking care not to mistake the (+) and (-) polarity.
- ⑤ Attach the rear case, tighten the screw and set the stand and holster to their original positions.

<How to replace the fuse>

Fuse of the Specified Rating and Type

(Fuse with arc-extinguishing agent)

400 mA/1000 V ϕ 6.3×32 mm Blowout capacity:30 kA (ceramic tube fuse)

16 A/1000 V ϕ 10×38 mm Blowout capacity:30 kA (ceramic tube fuse)

- ① Remove the holster from the main unit.
- ② Open the stand on the rear of the main unit and remove the rear case retaining screw using a Phillips screwdriver.
- ③ Remove the rear case as if flapping it up from the bottom, and take out the blown fuse.
- ④ Insert a brand-new fuse.
- ⑤ Attach the rear case, tighten the screw and set the stand and holster to their original positions.

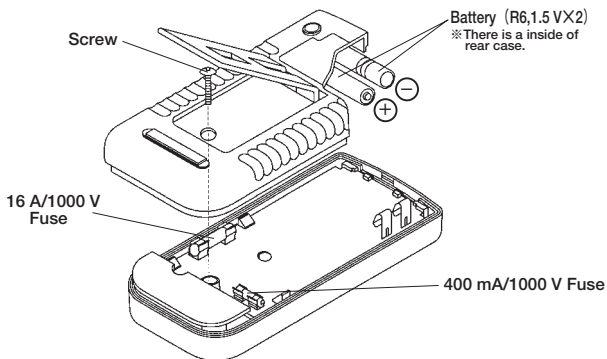

6-4 Cleaning and Storage

⚠ CAUTION

1. The panel and the case are not resistant to volatile solvent and must not be cleaned with thinner or alcohol.
For cleaning, use dry, soft cloth and wipe it lightly.
2. The panel and the case are not resistant to heat. Do not place the instrument near heat-generating devices (such as a soldering iron).
3. Do not store the instrument in a place where it may be subjected to vibration or from where it may fall.
4. For storing the instrument, avoid hot, cold or humid places or places under direct sunlight or where condensation is anticipated.

Store the instrument in a favorable environment (see 7-2 on page 59) by observing the caution above.

[7] SPECIFICATIONS

7-1 Measurement Range and Accuracy

Accuracy assurance range : $23 \pm 5^\circ\text{C}$ 80 %RH MAX. No condensaiton.

Function	Range	Input Impedance	Accuracy	Remarks
DCV	600.0 mV	$\geq 100\text{ M}\Omega$	$\pm (0.5\% \text{rdg} + 2 \text{dgt})$	
	6.000 V	Approx. 11 M Ω	$\pm (0.9\% \text{rdg} + 2 \text{dgt})$	
	60.00 V	Approx. 10 M Ω		
	600.0 V			
ACV	1000 V			<ul style="list-style-type: none"> Accuracy guaranteed range: 45 Hz to 500 Hz, with sine-wave AC
	6.000 V	Approx. 11 M Ω	$\pm (1.2\% \text{rdg} + 9 \text{dgt})$	
	60.00 V	Approx. 10 M Ω	$\pm (1.2\% \text{rdg} + 5 \text{dgt})$	
	600.0 V		$\pm (1.5\% \text{rdg} + 5 \text{dgt})$	
Hz	750 V			<ul style="list-style-type: none"> Accuracy guaranteed range: 5 Hz to 99.99 kHz, 5 Vrms to 100 Vrms sine-wave AC (zero-cross sin signal waveform). No bar graph display. Auto range only.
	9.999 Hz	Approx. 11 M Ω or approx. 10 M Ω (depending on ACV range during measurement)	$\pm (0.5\% \text{rdg} + 3 \text{dgt})$	
	99.99 Hz			
	999.9 Hz			
	9.999 kHz			
99.99 kHz				
Duty	20.0 to 80.0% Pulse width/ Pulse interval		$\pm (0.5\% \text{rdg} + 5 \text{dgt})$	<ul style="list-style-type: none"> Accuracy guaranteed range: 5 Hz to 1 kHz, 5 Vp-p to 60 Vp-p rectangular wave AC (zero-cross pulse waveform). No bar graph display. Auto range only.
DCA	600.0 μA	Approx. 50 Ω	$\pm (1.5\% \text{rdg} + 3 \text{dgt})$	<ul style="list-style-type: none"> Continuous measurement permissible range: (> 6 A: Measurement time < 10 sec., measurement interval \geq 5 min.) Input resistance not included in input resistance.
	6000 μA			
	60.00 mA	Approx. 0.5 Ω	$\pm (2.0\% \text{rdg} + 3 \text{dgt})$	
	600.0 mA	Approx. 0.05 Ω		
	6.000 A			
15.00 A				
ACA	600.0 μA	Approx. 50 Ω	$\pm (1.8\% \text{rdg} + 5 \text{dgt})$	<ul style="list-style-type: none"> Accuracy guaranteed range: 45 Hz to 500 Hz sine-wave AC. Continuous measurement permissible range: (> 6 A: Measurement time < 10 sec., measurement interval \geq 5 min.) Input resistance not included in input resistance.
	6000 μA			
	60.00 mA	Approx. 0.5 Ω	$\pm (2.5\% \text{rdg} + 5 \text{dgt})$	
	600.0 mA	Approx. 0.05 Ω		
	6.000 A			
15.00 A				
Ω	600.0 Ω		$\pm (1.5\% \text{rdg} + 5 \text{dgt})$	Open voltage Apporox DC 0.63 V
	6.000 k Ω		$\pm (1.2\% \text{rdg} + 4 \text{dgt})$	
	60.00 k Ω			
	600.0 k Ω		$\pm (1.8\% \text{rdg} + 2 \text{dgt})$	
	6.000 M Ω			
	60.00 M Ω		$\pm (3.0\% \text{rdg} + 2 \text{dgt})$	
•••	Buzzer beep and lamp lighting at 10 Ω to no more than 60 Ω . Open voltage Approx DC 0.63 V			
→	Open voltage Approx DC 2.7 V			No bar graph display.
μF	40.00 nF		$\pm (5\% \text{rdg} + 6 \text{dgt})$	No bar graph display. Auto range only
	400.0 nF			
	4.000 μF			
	40.00 μF		$\pm (7\% \text{rdg} + 10 \text{dgt})$	
	400.0 μF			
4000 μF				

rdg : reading dgt : digits

◎Accuracy calculation method

Example) DC voltage measurement (DC mV)

True value: 100.0 mV

Range accuracy: 600 mV range - $\pm(0.5 \% \text{rdg} + 2 \text{dgt})$

Tolerance: $\pm(100.0 [\text{mV}] \times 0.5 \% + 2 [\text{dgt}]) = \pm 0.7 [\text{mV}]$

Displayed value: 100.0 [mV] ± 0.7 [mV] (within the range of 99.3 to 100.7 mV)

⚠CAUTION:

If there is presence of strong magnetic field generated by conductor fed large current, motors or strong radio wave, a measurement may not be accurate.

Specifications and external appearance of the product described above may be revised for modification without prior notice.

7-2 General Specifications

Measuring Method: $\Delta \Sigma$ method

Display : 6000 counts

Range selection : Auto and manual ranges

Over display : "O.L" is displayed
(except DC/AC 15 A, DC 1000 V, AC 750 V ranges)

Polarity : Automatic selection (only "-" is displayed)

Battery discharge display : If the internal battery has been consumed and the voltage drops, the display shows.

Sampling rate : Approx. 3 times/sec.
Bar graph: 30 times/sec.

Accuracy assurance temperature /humidity range : 23 ± 5 °C 80 %RH max. No condensation.

Operating temperature /humidity range : $5 \sim 40$ °C 80 %RH max. No condensation.

Storage temperature /humidity range : $-10 \sim 50$ °C 70 %RH max. No condensation.

Environmental condition: Operating altitude <2000 m, pollution degree II

Power supply : R6 (IEC) dry battery, 2 pieces

Power consumption: Approx. 7 mW TPY. (at DCV)

Battery life : Approx. 400 hours at DCV

Fuse protection : 400 mA/1000 V Fast acting fuse (ϕ 6.3×32 mm)

(Fuse with) Blowout capacity, 30 kA (ceramic tube fuse)

(arc-extinguishing) 16 A/1000 V Fast acting fuse(ϕ 10×38 mm)

(agent) Blowout capacity, 30 kA (ceramic tube fuse)

Dimension and Mass: 167(H) ×90(W) ×48(D)mm

Approx. 320 g (holster attached.)

Safety : EN61010-1, EN61010-2-030, EN61010-2-033.

CAT. III 600 V, CAT. II DC 1000 V, AC 750 V.

IEC61010-031.

EMC Directive, RoHS Directive

: EN61326-1(EMC), EN50581(RoHS)

Accessories : Instruction manual, Test leads(TL-25a), Holster (H-70)

Measurement categories (overvoltage categories)

CAT II :Primary cable runs of power-consuming equipments from a wall socket.

CAT III:Primary cable runs of equipments directly connected to a distribution board and cable runs from a distribution board to wall sockets.

CAT IV:Cable runs from an incoming line to a distribution board.

7-3 Optional accessories

- Clip adapter CL-15a· HV probe HV-60
- Clamp probe CL3000, CL-22AD, CL33DC
- Carrying case C-SP

[8] After-Sales Service

8-1 Warranty and Provision

Sanwa offers comprehensive warranty services to its end-users and to its product resellers. Under Sanwa's general warranty policy, each instrument is warranted to be free from defects in workmanship or material under normal use for the period of one (1) year from the date of purchase.

This warranty policy is valid within the country of purchase only, and applied only to the product purchased from Sanwa authorized agent or distributor.

Sanwa reserves the right to inspect all warranty claims to determine the extent to which the warranty policy shall apply. This warranty shall not apply to fuses, disposables batteries, or any product or parts, which have been subject to one of the following causes:

1. A failure due to improper handling or use that deviates from the instruction manual.
2. A failure due to inadequate repair or modification by people other than Sanwa service personnel.
3. A failure due to causes not attributable to this product such as fire, flood and other natural disaster.

4. Non-operation due to a discharged battery.
5. A failure or damage due to transportation, relocation or dropping after the purchase.

8-2 Repair

Customers are asked to provide the following information when requesting services:

1. Customer name, address, and contact information
2. Description of problem
3. Description of product configuration
4. Model Number
5. Product Serial Number
6. Proof of Date-of-Purchase
7. Where you purchased the product
- 1) Prior to requesting repair, please check the following:
Capacity of the built-in battery, polarity of installation and discontinuity of the test leads.
- 2) Repair during the warranty period:
The failed meter will be repaired in accordance with the conditions stipulated in 8-1 Warranty and Provision.
- 3) Repair after the warranty period has expired:
In some cases, repair and transportation cost may become higher than the price of the product. Please contact Sanwa authorized agent / service provider in advance.
The minimum retention period of service functional parts is 6 years after the discontinuation of manufacture. This retention period is the repair warranty period. Please note, however, if such functional parts become unavailable for reasons of discontinuation of manufacture, etc., the retention period may become shorter accordingly.
- 4) Precautions when sending the product to be repaired:
To ensure the safety of the product during transportation, place the product in a box that is larger than the product 5 times or more in volume and fill cushion materials fully and then clearly mark "Repair Product Enclosed" on the box surface. The cost of sending and returning the product shall be borne by the customer.

8-3 SANWA web site

<http://www.sanwa-meter.co.jp>

E-mail: exp_sales@sanwa-meter.co.jp

MEMO

sanwa®

三和電気計器株式会社

本社=東京都千代田区外神田 2-4-4・電波ビル
郵便番号=101-0021・電話=東京(03)3253-4871(代)

大阪営業所=大阪市浪速区恵美須西2-7-2
郵便番号=556-0003・電話=大阪(06)6631-7361(代)

SANWA ELECTRIC INSTRUMENT CO., LTD.

Dempa Bldg, 4-4 Sotokanda 2-Chome Chiyoda-Ku, Tokyo, Japan



植物油インキを使用しています。

06-1710 2040 2040