Contents

Chapter 1 Safety Information

◎ Meter Safety Standards.....	1
◎ Warning.....	1
◎ Limited Guarantee and the Liability Range.....	2

Chapter 2 Introduction to the Meter

◎ Characteristics.....	3
◎ Explanation on Front Panel.....	4
◎ Understanding Display Screen.....	7
◎ Function Descriptions.....	10

Chapter 3 Operation Methods

◎ DCV Measurement.....	12
◎ ACV Measurement.....	14
◎ DC mV/AC mV Measurement.....	16
◎ Logic Frequency/Duty Ratio Measurement.....	18
◎ Resistance/continuity/ Diode Measurement.....	20
◎ Capacitance Measurement.....	22
◎ Temperature Measurement.....	24
◎ DC μ A /AC μ A Measurement.....	24

Contents

◎ DC mA/AC mA Measurement.....	26
◎ DC Ampere/AC Ampere Measurement.....	28
◎ Linear Frequency Measurement.....	30
◎ Relative Value Measurement.....	31
◎ Maximum Value/Minimum Value Measurement.....	31
◎ PEAK max/min measurement.....	32
◎ Backlight Control.....	32
◎ Data Hold.....	32
◎ Automatic Shutdown and Continuous Operation Mode Selection.....	33
◎ Connected to USB Interface Of Computer.....	33
Chapter 4 Technological Specifications	
◎ General Features.....	34
◎ Range and Accuracy.....	35
Chapter 5 Maintenance	
◎ Replacement of Batteries.....	40
◎ Replacement of Fuse.....	40
◎ Others	41

Chapter 1 Safety Information

Meter Safety Standards

This style of digital multimeter is designed and manufactured according to the safety requirements set out by the IEC61010-1 standards for electronic test instruments and the hand-held digital multimeters. Its design and manufacture is strictly based on the provisions in the 1000V CAT II of IEC61010-1 and the Stipulation of 2-Pollution Grade.

The meter conforms to the European Union's following requirements:89/336/EEC (EMC Electromagnetic Compatibility),73/23/EEC (LVD Low Voltage Protection) and 93/68/EEC (CE Mark).



Warning

- Before using the meter firstly checkup if there is any crack on the outer shell or if it lacks any plastic part, and checkup whether the testing line is damaged or has any exposed metal. The meter can be used only if no any insulating problem be found.
- Carefully read the operating methods and safety prompts in this manual. Using it not based on the methods specified in this manual may cause damage of the meter.
- Don't use the non-normal meter. You should have it repaired.
- Don't use it in the environment with combustible gases, steam, or dust pollution.
- Measure carefully when the voltage is higher than 30Vac (effective value) or 50Vdc for such voltage having the risk of shock. Avoid the body directly touching ground or any metal substance in which there may be ground

Safety Information

potential during measuring. Keep the body should be kept insulated from ground with dry insulating shoes, insulating pads or insulating clothes.

- When measurement with a test probe your fingers should be put behind a finger-protector.
- Don't try to measure a voltage higher than 1000VAC or 1000VDC, the meter may be damaged and the operator's safety may be threatened if the limit for voltage measurement is exceeded.
- When the symbol of electric insufficiency appearing on the display screen it is necessary to replace the batteries for avoiding the possible shock or injure resulted in by erroneous reading.
- In case of replacing batteries, it is necessary firstly to pull out the testing line. AAA batteries should be used and they should be put into the meter with the proper polarity.
- Don't make any voltage measurement when the testing line being inserting into the current hole.
- The repair and calibration of the meter must be carried out by experienced professionals, others should not repair and calibrate the meter by themselves.

Limited Guarantee and the Liability Scope

The company will undertake to repair freely any quality problem of the meter within 18 months from the date when it was bought, except for the replacement of fuse and batteries as well as any damage caused by negligence, wrong use, pollution, change of circuit and non-normal use.

Please offer the invoice before maintenance. for the maintenance beyond the 18-month guarantee period, the company will charge some repair fee and materials cost.

Chapter 2 Introduction to the Meter

Characteristics

- 22000 counts measurement
- ACV and DCV measurements reach up to 1000V.
- DC measurement accuracy reaches up to 0.05%.
- 0.01 Ω resistance resolution and 10 μ V voltage resolution.
- Linear frequency measurement, logic frequency/duty ratio measurement.
- Capacitance measurement from 0.001nf to 220mF.
- AC true RMS measurement. (Only model S)
- Temperature Measurement.
- Maximum value/minimum value measurement, Relative measurement, PEAK max/min measurement.
- 46-segment analog bar display.
- Automatic shutdown/continuous working mode selection.
- Back light control.
- PC-LINK: USB infrared interface.
- Display, record and graphics software of computer.
- Overload protection.
- Sound alarm for wrong current measurement.
- Secondary plasticizing meter shell, with insulating performance reaching 1000V CAT II

Introduction to the Meter

Explanation on Front Panel

The front panel is shown as in Figure 2-1, explanation being as follows:

Figure 2-1

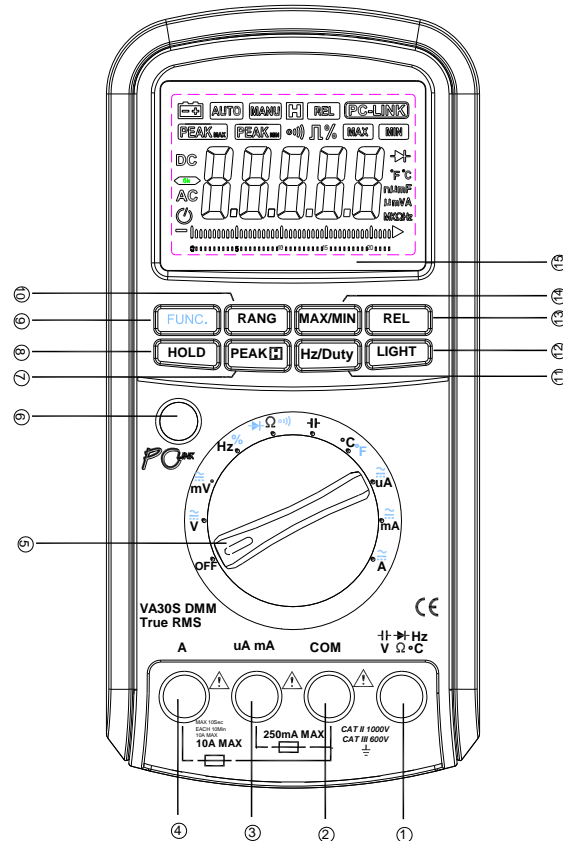

(1) V/ Ω /°C/CAP/DIODE/Hz end

It is the input end for all measurement functions except for current measurement, connected with a red meter probe.

(2) COM end

It is the negative input end for all measurements, connected with a black meter probe.

(3) μ A/mA end

It is the positive end for measurement of μ A or mA current, connected with a red meter probe.

(4) A end

It is the positive input end for measurement of 0.22A-10A current, connected with a red meter probe.

(5) Rotary switch

Used for selecting measurement functions such as Power off, voltage, current, resistance, temperature and capacitance.

(6) PC-link switch

Used for connect PC for record the measurement value.

(7) PEAK-H key

Used for measuring PEAK-max, PEAK-min when input AC signal.

(8) HOLD key

Used to maintain the measurement data unchanging, by pressing the key again it will resume the measurement. Pressing this key and last for 2 seconds, the meter will delay for 6 seconds, then enters HOLD mode.

Introduction to the Meter

(9) FUNC. key

When setting the rotary switch to a measurement function, the meter will enter its first measurement mode, while pressing the **FUNC.** key it is possible to select the second or the third measurement mode. However, there is only one for the Frequency and Capacitance measurements.

(10) RANGE key

For various kinds of measurements, it is used manually to select range. Under the automatic range state (AUTO displaying), it will enter manual range state (MANUAL displaying) with a press on **RANGE**, after that the range will be changed with a press on **RANGE** while the small digits on the left lower corner indicating the actual range. When the **RANGE** key being released after pressing for one second the meter will return to the automatic state.

(11) Hz/DUTY key

During the AC voltage or AC current measurements, by pressing **Hz/DUTY** key the meter will enter the linear frequency measurement state. At this time what being measured is the frequency of voltage or current. By pressing this key again, it will enter the **DUTY** Cycle measurement state, by pressing this key again it will return the voltage or current measurement state. But if it during the Frequency measurements state, by pressing **HZ/DUTY** key the meter will enter **DUTY** Cycle measurement state, pressing again it will be returned.

(12) LIGHT key

By pressing this key for a time, the backlight of the LCD screen will be opened and after 60 seconds the meter will automatically turn off the backlight. It is also possible to turn off the backlight by pressing the **LIGHT** key before the 60 seconds.

(13) REL key

By pressing REL to enter the relative measurement state, the meter will remember the value measured at the time when pressing the key (it is called the initial value), and after that the value displayed in the meter will be equivalent to the present value minus the initial value. By pressing the key again, the relative measurement state will be exited. Pressing the key will be void during the frequency and diode measurements.

(14) MAX/MIN key

Press MAX/MIN key to enter the record state for the maximum and minimum value and simultaneously display the maximum value. When this key is pressed again, the meter displays the minimum value, when this key is pressed for the third time, the current value will be displayed. When releasing the key after pressing it for one second, the maximum and minimum record state will be exited. Pressing this key will be void during frequency and diode measurement.

(15) LCD screen

Used for displaying the measuring results and various symbols.





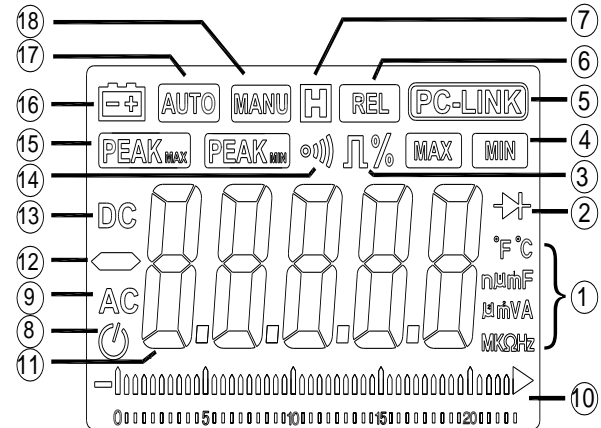

Understanding Display Screen:







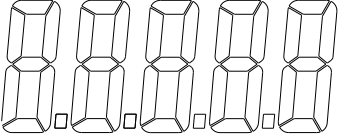

LCD screen is shown as in Figure 2-2, with its every symbol's meaning shown as in the Table 1:

Figure 2—2:



Introduction to the Meter

Number of Order	Symbol	Functions
1	°C °F	Indicating the measurement unit being °C or °F of temperature
1	n μ mF	Indicating the measurement unit being nF, μ F or mF of Capacitance
1	μ m VA	Indicating the measurement unit being μ A, mA, A or V of current and voltage
1	MKΩHz	Indicating the measurement unit being M Ω ,K Ω and Ω of resistance or MHz, KHz and Hz of frequency
2		Indicating it is now performing the Diode measurement
3		Indicating it is now performing the DUTY Cycle measurement
4		Indicating the display value being the maximum value (MAX), the minimum value (MIN)
5		Indicating the meter being in the state for sending data to the USB interface of computer
6		Indicating the measurement being relative measurement while the displayed value being relative value
7		Indicating it is now in the data-holding state
8		Indicating AUTO POWER OFF is available
9	AC	Indicating it is now in the AC measurement state.

Tabell (continue)		
10		Analog bar, indicating the measurement value with a graphic mode
11		The display zone for the meter's measurement value, showing all the measurement values
12		Indicating the measurement vale being negative
13		Indicating it is now in the DC measurement state
14		Indicating it is now performing the continuity measurement
15		Indicating the display value being the PEAK maximum value, the PEAK minimum value
16		Indication to low voltage of the batteries, showing the energy of batteries will be exhausted soon
17		Indicating the measurement being automatic range
18		Indicating the measurement being manual range

Introduction to the Meter

Function Descriptions

Along with the conventional measurement functions this meter also possesses some special functions which being described as follows:

- **True effective value (TRUE RMS) measurement:** all the measurement values of this meter on the AC voltage and AC current are true effective values, which distinguishing this meter from the low-grade meters which only can measure the AC average value. (Only model S)
- **Automatic and manual ranges:** When turning on the meter's power switch the meter defaults the automatic range state (AUTO displaying), and simultaneously it will automatically select the proper range according to the measured electric parameters. If OL being displayed under automatic range, it indicates the measured value exceeding the meter's maximum range. Pressing the RANGE key under the automatic range the meter will enter the manual range (MANUAL displaying), then pressing the RANGE key again it will be possible to select the required range. The indicator for range will display the maximum value of this range. If OL displaying under the manual range, it indicates the measured value exceeding the selected range. Press the RANGE key under the manual range for two seconds and then release it, the meter will go back to the automatic range state.
- **Linear frequency measurement:** Pressing the HZ/DUTY key when the meter performing measurements on AC voltage or current.
- **Logic impulse duty ratio measurement:** logic impulse duty ratio refers to: $(\text{high level width}/\text{impulse cycle}) \times 100\%$.
- **Diode measurement:** during diode measurement the meter is indicating to the forward voltage drop of the diode
- **Relative measurement:** during relative measurement the meter remembers internally the instantaneously measured value (called initial value) when pressing the REL key, and the later displaying value being:

present value – initial value

The relative measurement value reflects the changes of the measured value. It also can be used to take off the errors brought about by lead resistance or distributed capacitance during measuring low resistance and low capacitance.

- **Maximum/minimum value measurement:** by pressing MAX/MIN keys the meter can enter the maximum/minimum value record state, and it will continuously update the maximum/minimum values based on the new measurement results.
- **Auto power off:** The meter will automatically turn off after fifteen minutes, unless pressing any key or changed the rotary switch. And in this case, the energy consumption still exists, but is very little. if the meter is restarted by pressing any key, except HOLD, the last metrical data will be displayed on the LCD. and changing the rotary switch can also restart the meter, but the last number will be cleared away. If the PC-LINK is in the work, the AUTO POWER OFF will not be happened and the meter will be operated continuously
- **Low voltage detection:** when the meter detecting the total voltage of the batteries lower than 7V, the  symbol on the LCD screen will be lighted to prompt the batteries should be replaced.
- **Analog indication bar:** analog indication bar is used for graphic measurement value and it always synchronizes with the size of the present measured value. During the maximum value/minimum value measurement and the relative value measurement it sill synchronizes with the size of the present measured value, and not indicating the maximum value/minimum value or the relative value.
- **PC-LINK:** press down the PC-LINK key, the meter will open the infrared interface for sending the measured data and status to the computer. Equipped with record and graphic software (options)the meter can display, record, and describe the measured electric quantity on computer. As the data transmission between the meter and computer is depending on light coupling, so measurement of high voltage will not affect the safety of computer.

Introduction to the Meter

- **PEAK-H:** It has calibration for peak mode, peak max value, and peak min value mode.
- **Delay HOLD:** When releasing the HOLD key after pressing it for two seconds, the meter will delay for 6 seconds, then enter HOLD mode. By this way you could better operation than other way for hold on the metrical data

Chapter 3 Operation Methods

DCV Measurement

The measurement is shown in Figure 3-1, the range of voltage is of DC 0.23V~1000V and the methods are as follows:

1. Switch and set the rotary-table switch to the position $\tilde{V}\cdot$.
2. Insert the red testing line into the **VΩ°C** end and the black testing line into the **COM** end.
3. When performing DCV measurement, connect the red probe to the positive polarity of the measured voltage and the black probe to the negative polarity of the measured voltage.
4. Read the measured value from the display screen. If OL displaying on the meter, it indicates the measured voltage exceeding the range of the meter and it is necessary to remove the both red and black probes from the measured circuit immediately.
5. When performing DCV measurement, by pressing the **RANGE** key it is possible to select range manually. If OL displaying during manual range measurement, it is necessary to select a larger range. If OL displaying under the maximum range, it indicates the voltage exceeding 1000V and it is necessary to remove the both red and black probes from the measured circuit immediately.

12 Notes: in case of probe hanging in the air, the voltage inducted by the testing line may cause unstable readings on the display screen.

but that will not affect the accuracy of measurement.

Figure 3-1:

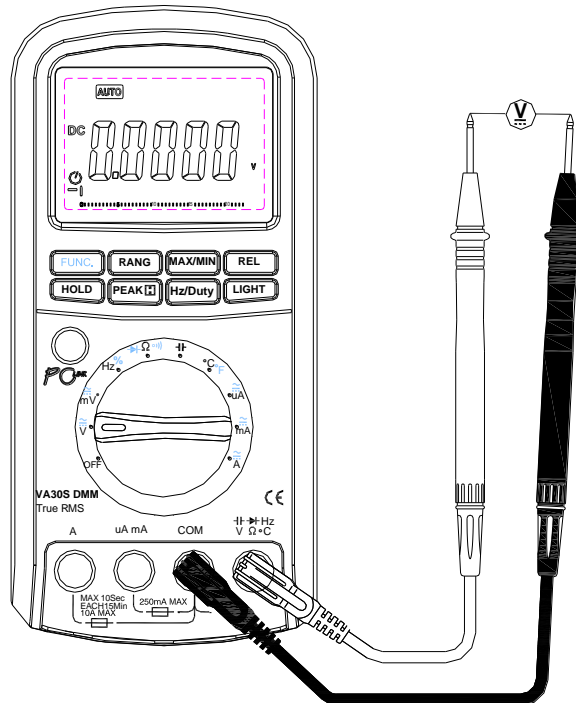

DCV Measurement



Warning

Not try to measure
a voltage higher than
1000 vlt

Operation Methods

ACV Measurement

The measurement is shown as in Figure 3-2, with voltage range being of AC 0.23V~1000V and the measurement methods being as follows:

1. Turn on the power switch and set the rotary switch to the position of \tilde{V} .
2. Insert the red and black testing lines into **VΩHz** end and **COM** end respectively.
3. Press **FUNC.** key to select **ACV** measurement mode.
4. Connect the meter to the two ends of the measured voltage with the red and black probes.
5. Read the meter's data from the display screen. When OL displaying on the meter, it indicates the measured voltage exceeding the meter's range and it is necessary to remove both the red and black probes from the measured circuit immediately.
6. By pressing the **RANGE** key, it is possible to select range manually. Indicator of range displays range. While displaying OL during manual range measurement, it is necessary to select a larger range. When OL displaying under the maximum range, it indicates the voltage exceeding 1000V, so it is necessary to remove both the red and black probes from the measured circuit immediately.

Notes: in case of probe hanging in the air, the voltage inducted by the testing line may cause unstable readings on the display screen, but that will not affect the accuracy of measurement.

Figure 3-2:

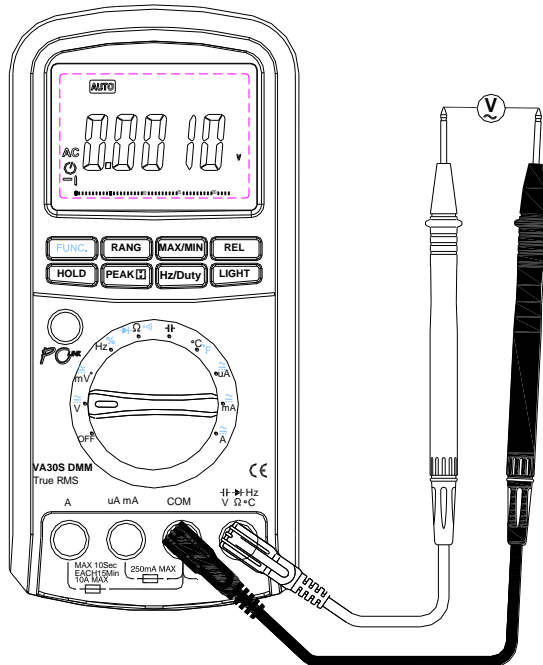

AC Measurement



• **Warning**

**Not try to measure
a voltage higher than
1000 volt**

DC mV/AC mV Measurement

The testing chart is shown in the Figure 3-3. The voltage measurement range is of $10\ \mu\text{V}\sim 220\text{mV}$ and the measurement methods are as follows:

1. Turn on the power switch and set the rotary switch to the position $\text{m}\overset{\sim}{\text{V}}\bullet$.
2. Insert the red testing line into the **VΩHz** end and the black testing line into the **COM** end.
3. Press the **FUNC.** key to select **DCmV** measurement modes.
4. When performing **DCmV** or **ACmV** measurement, connect the red probe to the positive polarity of the measured voltage and the black probe to its negative polarity.
5. Read the measured value from the display screen. If OL displaying on the meter, it indicates the measured voltage exceeding the range of the meter and it is necessary to remove both the red and black probes from the measured circuit immediately.
6. In this mode, it is null to press the **RANGE** key

Notes:

a)In case of probe hanging in the air, the voltage inducted by the testing line may cause unstable readings on the display screen, but that will not affect the accuracy of measurement.

b)The meter is a true rms responding meter. When the input leads are shorted together in the ac function, the Meter may display a residual reading between 1 and 30 counts. It will not affect stated accuracy, But if using REL to offset this reading may produce a much larger constant error in later measurements. (Only model S)

Figure 3-3:

DC/AC mV Measurement:

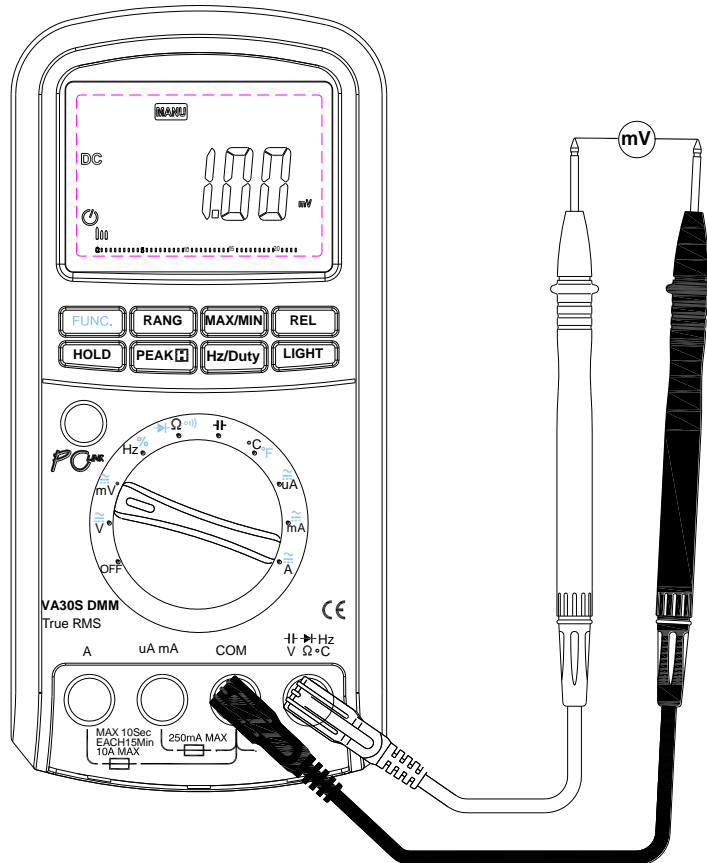

Logic Frequency/Duty Ratio Measurement

The testing chart is shown in the Figure 3-4. The frequency range is of 2.01Hz~10MHz (V_p 2~5V), while the duty ratio measurement range being of 5%~94.9%. And the measurement methods are as follows:

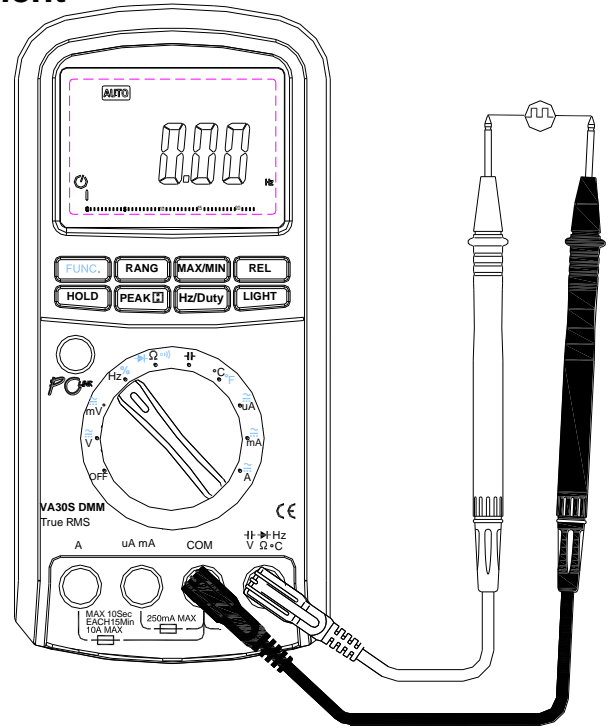

1. Turn on the power switch and set the rotary switch to the position $\text{Hz}\%$.
2. Insert the red testing line into the **VΩHz** end and the black testing line into the **COM** end.
3. Press the **HZ/DUTY** key to select the duty ratio (%) modes.
4. Connect the red testing line to high logic level, the black one to low logic level.
5. Read the measured value from the display screen. If the frequency of the measured signal is lower than 2.01Hz, the reading will be displayed as zero. If the amplitude of signal is too low or the low level is larger than 2 volts, the reading will also display as zero.
6. If the frequency of the duty ratio is lower than 5%, the reading will be displayed as UL. If the duty ratio is bigger than 95% the reading will also display as OL.
7. This measurement is of automatic range or manual range, it is available to press the **RANGE** key.

Figure 3-4:
Logic Frequency/Duty Ratio Measurement



Resistance/continuity Test/Diode Measurement

The test chart is seen in Figure 3-5. the measurement range of resistance is of $0.01 \Omega \sim 220M \Omega$ and the measurement methods are as follows:

1. Turn on the power switch and set the rotary switch to the position .
2. Insert the red and black testing lines into the **VΩH** input end and the **CÔM** input end respectively.
3. Press the **FUNC**, key to select resistance (Ω), the continuity () or the diode measurement() modes
4. For the Resistance measurement, connect the red and black probes to the two ends of resistor and read the resistance value from the display screen. If OL displaying, it indicates the resistor is larger than $220M \Omega$. As for the Continuity measurement, connect the red and black probes to the two measured points respectively. In case of the resistance between the two points being less than about 30Ω , the buzzer will sound while the display screen displaying the value of resistance. As for the Diode measurement, connect the red and black probes to the positive and negative polarity. while the display screen will display the forward voltage drop. If the forward voltage drop is larger than 2V the OL will be displayed. When the resistance measurement mode being implemented, it is possible to select range by pressing the RANGE key. The indicator of range indicates the value of range. If OL displaying during manual range measurement, it is necessary to select a larger range. Under the continuity measurement mode, it is null to press the **RANGE** key.

Notes: In case of performing resistance ,continuity or diode test on circuit board, it is necessary firstly to turn off the power of the circuit board and then perform the measurement. As there may be other parallel circuits, so the displayed value of test is not surely the actual value of the resistor.

Capacitance Measurement

The measurement chart is seen in figure 3-6. the measurement range of capacitance is of 10PF~220mF and the measurement methods are as follows:

1. Turn on the power switch and set the rotary switch to the position .
2. Insert the red and black testing lines into the **VΩHz** input end and the **COM** input end respectively.
3. If exists voltage in the capacitor, connect the two ends of the capacitor for a short time to discharge.
4. Connect the red and black probes to the two ends of the capacitor, if the measured capacitor is heteropolar, it is necessary to connect the red probe to the positive polarity of the capacitor and the black probe to its negative polarity.
5. Read the capacitance from the display screen. If capacitance value >220mF, the meter will display OL, while capacitance value <10PF, it will display zero.
6. It is possible to select range manually by pressing the **RANGE** key. The indicator of range indicates the value of range. If OL displaying during manual range measurement, it is necessary to select a larger range. If it has been the largest range, which means capacitance value >220mF.

Notes: When performing measurement on 10mF capacitor, in order to ensure measurement accuracy, the meter takes a relative long time to discharge capacitor, so it is relatively slow in refreshing the measured value. In addition, not to perform Capacitance measurement on a circuit board on which there are other parallel devices, for that may leads to very large error.

Figure 3-6

Capacitance Measurement:

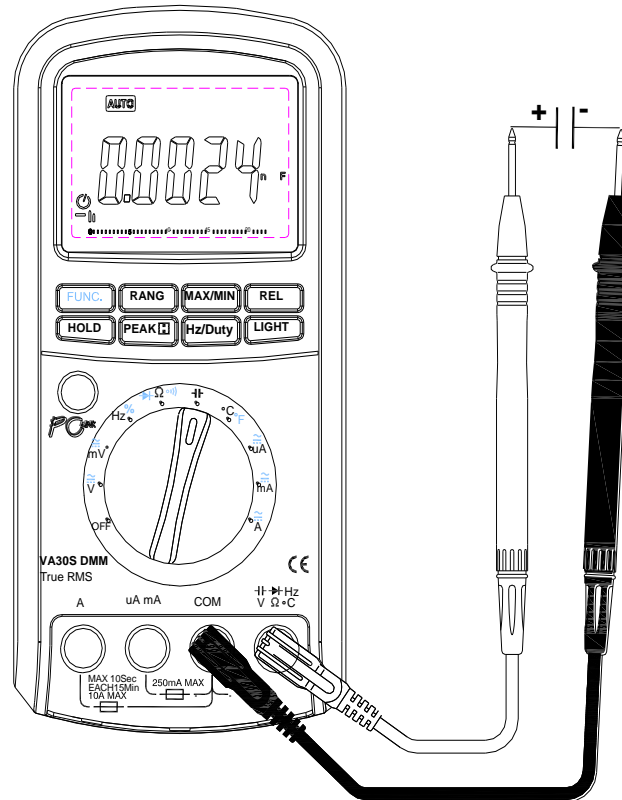

Operation Methods

Temperature Measurement:

1. Turn on the power switch and set the rotary switch to the position °C.
2. The 'LCD' display will show the approx. current environment temperature.
3. Press the **FUNC.** key to select the °C or °F measurement modes.
4. When measuring the temperature with thermocouple, 'K' type probe for this meter can be used. Insert the black plug to the COM jack and the red one to the °C jack, touch the end of the temperature sensor to the area or surface of the object for measurement.
5. You can get reading from LCD.

DC/AC μ A Measurement:

The measurement is seen in Figure 3-8, the measurement range of current is of AC or DC 0.01 μ A ~ 2200 μ A , and the measurement methods are as follows:

1. Turn on the power switch and set the rotary switch to the position μ A.
2. Insert the red testing line into the mA/ μ A input end and the black testing line into the COM input end.
3. Press the **FUNC.** key to select the **Dc μ A or Ac μ A** measurement modes.
4. Turn off the power of the measured circuit, connect the red and black probes to the measured circuit in serial way and then turn on the power of the measured circuit.
5. Read the measured value from the display screen. If it displays as positive during the DC measurement, it means the current is flowing into the meter from the red testing line, while it displaying as negative, it means the current is flowing into the meter from the black testing line. If it displays as OL, it means current exceeding range.
6. During measurement of **DC μ A or Ac μ A**, it is possible to select range manually by pressing the RANGE key.

Notes: In this mode the Meter may display a initial reading between 1 and 5 counts when no signal input, but that will not affect the

accuracy of measurement. Using REL to offset this reading may produce a much larger constant error in later measurements.

Figure 3-8

DC/AC μ A Measurement:

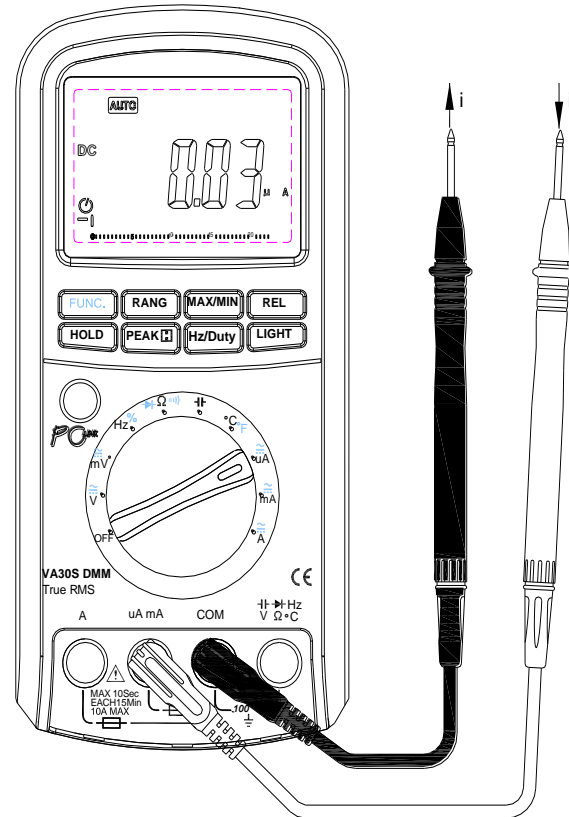

Operation Methods

DC/AC mA Measurements

The measurement is seen in the Figure 3-9 The measurement range of current is of AC or DC 1 μ A~220mA and the measurement methods are as follows:

1. Turn on the power switch and set the rotary switch to the position  mA .
2. Insert the red testing line into the **mA/ μ A** input end and the black testing line into the COM input end.
3. Press the **FUNC.** key to select the **DC mA** or **AC mA** measurement modes.
4. Turn off the power of the measured circuit, connect the red and black probes to the measured circuit in a serial way and then turn on the power of the measured circuit again.
5. Read the measured value from the display screen. If it displays as positive during DC measurement, it means the current is flowing into the meter from the red testing line, while it displays as negative, it means the current is flowing into the meter from the black testing line. If it displays OL, indicating current exceeding range.
6. When performing **DC mA** or **AC mA** measurement, it is possible to select range manually by pressing the RANGE key.

Notes: In this mode the Meter may display a initial reading between 1 and 5 counts when no signal input, but that will not affect the accuracy of measurement. Using REL to offset this reading may produce a much larger constant error in later measurements.

Figure 3-9

DC/AC mA Measurement:

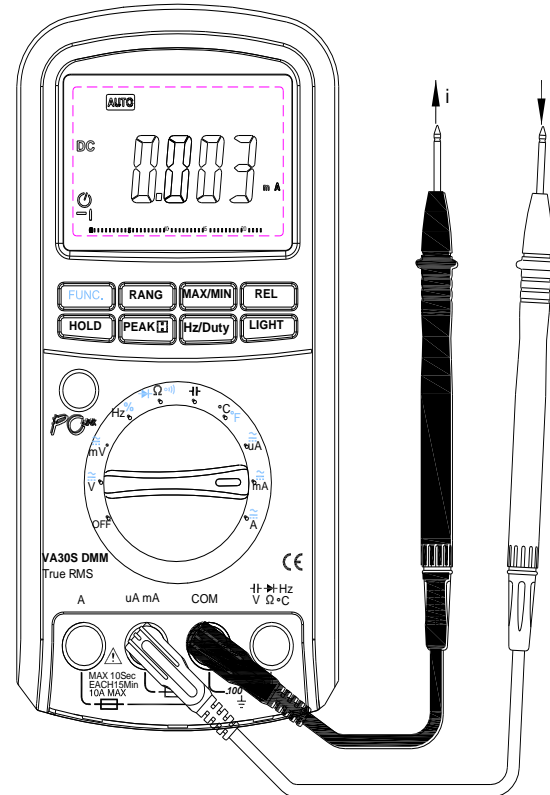

Operation Methods

DC /AC A Measurement

The measurement is seen in Figure 3-10, the measurement range of current is of AC or DC 1mA~10A and the measurement methods are as follows:

1. Turn on the power switch and set the rotary switch to the position .
2. Insert the red testing line into the A input end and the black testing line into the **COM** input end.
3. Press the **FUNC.** key to select the **DC A** or **AC A** measurement modes.
4. Turn off the power of the measured circuit, connect the red and black probes to the measured circuit in a serial way and then turn on the power of the measured circuit again.
5. Read the measured value from the display screen. During the **DC** measurement, if it displays as positive, it means the current is flowing into the meter from the red testing line, while it displays as negative, it means the current is flowing into the meter from the black testing line. If it displays OL, it indicates current exceeding range.
6. When performing **DC A or AC A** measurement, it is null to press the **RANGE** key.

Figure 3-10

DC/AC A Measurement:

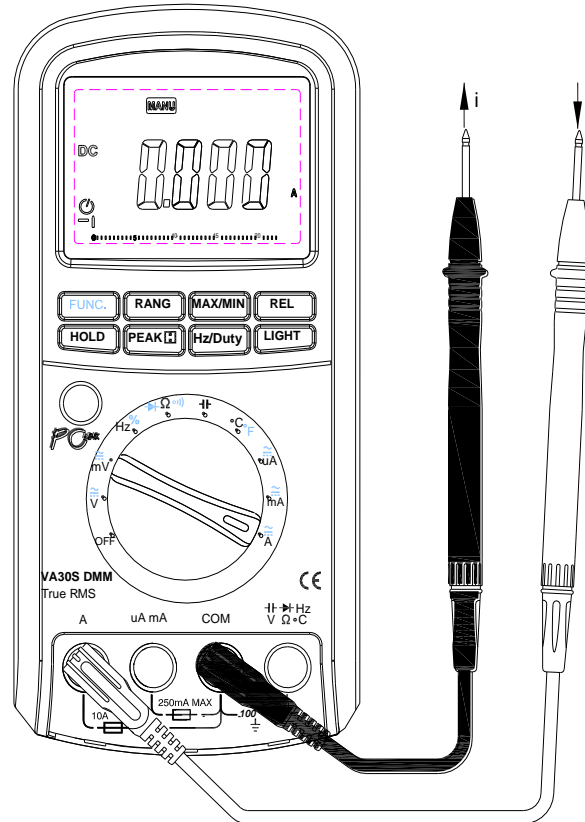

Operation Methods

Linear Frequency Measurement

The measurement range is of 5Hz~200KHz and the measurement methods are as follows:

1. When performing voltage or current measurement, in case of measured value being AC or including AC elements, it is possible to measure and display the alternating frequency by pressing the **Hz/DUTY** key. However it has a certain requirements for the amplitude of alternating signal and the meter has varied requirements for signal amplitude when it is in different ranges, for information of which please refer to Table 3—1.
2. If the position of rotary switch is in ACV or DCV, after pressing **Hz/DUTY** key the **RANGE** key will invalidation.
3. Press **Hz/DUTY** key again to enter DUTY measurement mode.
4. Press **Hz/DUTY** key again to exit linear frequency.

Table 3-1

Range	Sensibility (sine wave)
220mV	100mV
2.2V	0.5V
22V	4V
220V	40V
1000V	400V

Relative Value Measurement

Except for frequency/duty ratio and diode measurements, all other measurements can employ relative measurement. Press **REL** key to enter relative measurement and the meter will record the initial value when pressing the key. And the later displayed value is:

$$\text{Displayed value} = \text{present measurement value} - \text{Initial value}$$

Press **REL** again to exit relative measurement. Changes of measurement value may be found in relative measurement which also can be used for the small resistance and the small capacitance measurements, for example, when performing resistance measurement, connect the red testing line and the black testing line in short, press the **REL** key to record the values of resistance (resistance of both the red and black lines), and after that performing resistance measurement again the lead resistance will have been taken off from the displayed value. When performing capacitance measurement, open the red and black testing line, press **REL** key to record the distributed capacitance, and after that performing capacitance measurement again, the distributed capacitance will have been taken off from the displayed value. During relative measurement, analog bar is always indicating the present measurement value but not the relative value. When measurement over, OL will display instead of showing the relative value.

Maximum Value/Minimum Value Measurement

Except for frequency and diode measurements, by pressing the **MAX/MIN** key the meter will enter the maximum value and minimum value record state and display the maximum value. The meter measures the present value and continuously judges if it is necessary to update the maximum or minimum value. Pressing the **MAX/MIN** key again it is possible to select displaying

Operation Methods

the minimum value, the current value or the maximum value. When the meter being in the maximum and the minimum value record state, the analog bar is always indicating the present measurement value but not the MAX/MIN value. Under the maximum and minimum value record state, press the **MAX/MIN** key for two seconds and then release it, the meter will exit the MAX/MIN record state. When measurement over, OL will display instead of showing the MAX/MIN value.

PEAK max/min Measurement

When you measure AC signal, by pressing the **PEAK** key less than 1second the meter will enter the Peak maximum value after it be calibration. pressing the **PEAK** key again (less than 1s) it will enter the Peak minimum value. By pressing the **PEAK** key for more than 1 seconds and release it, the meter will exit the PEAK max/min record state. When measurement over, OL will display instead of showing the PEAK max/min value.

Backlight Control

Pressing the **LIGHT** key, the LCD display screen's backlight will be lighted and after 60 seconds it will automatically go out. If press the **LIGHT** key again when the backlight is lighting, the backlight can be turned off in advance. Lighting the backlight will cause three-times higher energy consumption than the ordinary operation. So, by less use of backlight, power can be saved.

Data Hold

By pressing the **HOLD** key, it is possible to hold the measurement value and the state now of pressing the **HOLD** key. While pressing the key again data measurement will be resumed.

Automatic Shutdown and Continuous Operation Mode Selection

After turning on power, the meter will in default enter the auto-shutdown timing state. Within 15 minutes after stopping to press any key or turn the rotary switch, the meter will automatically turn off. After auto-shutdown, by pressing the **FUNC.** key or turning the rotary switch it is possible to wake the meter to resume operation. If you want the meter operates continuously without shutdown, it will be done by pressing the PC-LINK key.

Notes: After auto-shutdown there will still be a little electricity consumption in the meter, so it is recommended to turn off the power when the meter is to remain un-working for a long time.

Connected to Computer by USB Interface

Pressing the **PC-LINK** key, the meter will begin to send the measured data and state to computer while the LCD display screen displaying **PC-LINK** . Then it will be able to record、analyze、draw and print all the measurement on computer as long as you insert one end of the USB cable (options) into the front socket of the meter and another end into the computer USB interface and run the record and graphics software (options).And press the **PC-LINK** key again, the meter will stop to send data to computer, symbol **PC-LINK** on the LCD display screen will go out. When the meter sends data to computer it will cause the increase of the electricity consumption. So **PC-LINK** should be turned off when no need to transmit data.

Chapter 4 Technological Specifications

General Features

- Voltage between the measurement end and ground is of 1000V AC/DC. 1000V CAT II, 2th pollution grade.
- 22000 counts, automatic/manual range, basic sampling rate 2 t/s and 46 segment analog bar.
- When rotary switch being in the positions of mV, logic frequency, diode, resistance and capacitance, the maximum overload protection voltage will be 250V(effective value),while in the positions of μ A/mA the protection current being 0.25A,and in the position of A, the protection current being 10A.
- Over range indication OL.
- When the total voltage of batteries being lower than 7V, the symbol for battery display will be lighted.
- Fuse being 0.25A/250V, \varnothing 5X20 (μ A/mA end) and 10A/250V \varnothing 6X32 (A end).
- Six 7# AAA batteries X 1.5V.
- Infrared coupling USB interface.
- Operating temperature: 0 $^{\circ}$ C \sim 30 $^{\circ}$ C (relative humidity 0 \sim 80%)
31 $^{\circ}$ C \sim 51 $^{\circ}$ C (relative humidity 0 \sim 50%)
- Storage temperature: -20 $^{\circ}$ C \sim 60 $^{\circ}$ C (relative humidity \leq 80%)
- Altitude: operation less than 2000m,
 storage less than 10000m
- Volume: 200mm X 100mm X 40mm
- Weight: 560g

Range and Accuracy

The below-listed accuracies under different ranges refer to those which are guaranteed by the meter within one-year calibration, with normal use under the operating temperature of 18°C-28°C and relative humidity less than 80%.The presentation for accuracy is: \pm (**% reading digits + number of lower digits)

● **AC Voltage**

Range	Resolution	Accuracy
		40Hz-1KHz
220mV	0.01mV	$\pm(0.5\% + 20)$
2.2V	0.1mV	$\pm(0.8\% + 40)$
22V	1mV	$\pm(0.8\% + 40)$
220V	10mV	$\pm(0.8\% + 40)$
1000V	100mV	$\pm(0.8\% + 40)$

Notes:
a) In case of probe hanging in the air, the voltage inducted by the testing line may cause unstable readings on the display screen, but that will not affect the accuracy of measurement.
b) The meter is a true rms responding meter. When the input leads are shorted together in the ac functions, the Meter may display a residual reading between 1 and 30 counts. It will not affect stated accuracy, but if using REL to offset this reading may produce a much larger constant error in later measurements. (Only model S)

Notes: above accuracies can be guaranteed within 10%-100% of the full range.

Technological Specifications

● DC Voltage

Range	Resolution	Accuracy
220mV	0.01mV	$\pm(0.1\%+8)$
2.2V	0.1mV	$\pm(0.2\%+8)$
22V	1mV	$\pm(0.2\%+8)$
220V	10mV	$\pm(0.2\%+8)$
1000V	100mV	$\pm(0.2\%+8)$

Notes: above accuracies can be guaranteed within the full range.

● AC Current

Range	Resolution	Accuracy
		40Hz~400Hz
220 μ A	0.01 μ A	$\pm(1.0\%+20)$
2200 μ A	0.1 μ A	$\pm(1.0\%+20)$
22mA	1 μ A	$\pm(1.0\%+20)$
220mA	10 μ A	$\pm(1.0\%+20)$
10A	1mA	$\pm(1.5\%+30)$

Notes: above accuracies can be guaranteed within 10%-100% of the full range

● **DC Current**

Range	Resolution	Accuracy
220 μ A	0.01 μ A	$\pm(0.3\%+15)$
2200 μ A	0.1 μ A	$\pm(0.3\%+15)$
22mA	1 μ A	$\pm(0.3\%+15)$
220mA	10 μ A	$\pm(0.3\%+15)$
10A	1mA	$\pm(0.8\%+30)$

Notes: above accuracies can be guaranteed within the full range

● **Resistance**

Range	Resolution	Accuracy
220 Ω	0.01 Ω	$\pm(0.5\%+8)$
2.2K Ω	0.1 Ω	$\pm(0.8\%+20)$
22K Ω	1 Ω	$\pm(0.8\%+20)$
220K Ω	10 Ω	$\pm(1.0\%+40)$
2.2M Ω	100 Ω	$\pm(1.0\%+40)$
22M Ω	1K Ω	$\pm(1.2\%+40)$
220M Ω	100K Ω	$\pm(1.5\%+40)$

Notes: above accuracies can be guaranteed within the full range

Technological Specifications

● Temperature

Range	Resolution	Accuracy
-50°C ∼ 50°C	0.1°C	±(3.0%+3°C)
50°C ∼ 400°C	0.1°C	±(1.0%+3°C)
400°C ∼ 1000°C	0.1°C	±(2.5%+3°C)
-58°F ∼ 122°F	0.1°F	±(3.0%+37.4°F)
122°F ∼ 752°F	0.1°F	±(1.0%+37.4°F)
752°F ∼ 1832°F	0.1°F	±(2.5%+37.4°F)

● Capacitance

Range	Resolution	Accuracy
22nF	0.001nF	±(1.0%+20)
220nF	0.01nF	±(1.0%+20)
2.2 μF	0.1nF	±(1.0%+20)
22 μF	1nF	±(1.5%+20)
220 μF	0.01 μF	±(1.5%+20)
2.2mF	0.1 μF	±(2.5%+20)
22 mF	1 μF	±(3.0%+20)
220 mF	10 μF	±(5.0%+20)

Notes: above accuracies for film capacitor or better can be guaranteed within the full range.

● Diode

Range	Resolution	Accuracy
2.2V	0.1mV	approx. forward voltage of diode

● **Logic Frequency**

Frequency Range	Sensitivity	Accuracy
2Hz~10MHz	V _p 2 ~5V square wave	±(0.05%+8)

● **Linear Frequency**

Frequency Range	Voltage/Current Range	Sensitivity		Accuracy
		2Hz ~20KHz	20KHz~200KHz	
2Hz~200KHz (Sine wave)	220mV	150mV	150mV	±(0.05%+8)
	2.2V	0.15V	1V(≤70KHz)	
	22V	2V	7V(≤140KHz)	
	220V	25V	25(≤100KHz)	
	1000V	100V(≤20KHz)	50V(≥50KHz)	

Notes: Low voltage or low frequency would lower the accuracy.

● **Duty Ratio**

Duty Ratio Range	Resolution	Accuracy
5%~94.9%	0.1%	±(2%+10)

Chapter 5 Maintenance

Replacement of Batteries

If symbol  appears on the LCD screen during measurement, it indicates the total voltage of batteries being lower than 7V. For ensuring measurement accuracy, it is necessary to replace the batteries. Before the replacement, must take off the red and black testing lines from the measured circuit and turn off the power of the meter. Loose the fixing screws of the cover by a standard screwdriver, then remove the cover to take out all the old batteries, replacing them with the 7# batteries. Take care to put in the batteries as the polarity specified on the shell of the meter. Put the cover as its origin. The meter must not be used until the cover of batteries being put properly and locked in.

Replacement of Fuse

It must take off the red and black testing lines from the measured circuit and turn off the power of the meter before replacement of fuse. It should only use fuse of the same model and the same electric specifications. Two fuses must not be put wrong in positions during their replacement. And the meter must not be used until the cover of fuses being put properly and locked in.

Notes: generally, fuses will not be blown under the normal use of the meter. In case of blowing, it is necessary first to find out the reasons for the blowing and then take an account on the use of the meter. Generally, blowing may attribute to:

- Perform voltage measurement when the rotary switch being in the position of current.
- Current exceeds range.
- Fuse being 0.25A/250V, Ø5X20 (μ A/mA end) and 10A/250V Ø6X32 (A end).

Others

- In case of any default being found this meter must not be used continuously.
- When the meter needs repair, please send it to experienced professionals or the appointed maintenance department for repairing.
- It should use soft cloth but not organic solvents which have corrosive and dissolving effect on the shell of meter to clean the meter, and it should guard against water dropping into the meter.