

## **1. General instructions**

This instrument complies with IEC 61010-1 (61010-1@IEC: 2001), CAT. II 1000V and CAT. III 600V overvoltage standards. See Specifications.

To get the best service from this instrument, read carefully this user's manual and respect the detailed safety precautions.

International symbols used on the Meter and in this manual are explained in chapter 1.1.3

### **1.1 Precautions safety measures**

#### **1.1.1 Preliminary**

\* Measurement category III is for measurements performed in the building installation.

NOTE: Examples are measurements on distribution boards, circuit-breakers, wiring, including cables, bus-bars, junction boxes, switches, socket-outlets in the fixed installation, and equipment for industrial use and some other equipment, for example, stationary motors with permanent connection to the fixed installation.

\* Measurement category II is for measurements performed on circuits directly connected to the low voltage installation.

NOTE: Examples are measurements on household appliances, portable tools and similar equipment.

\* Measurement category I is for measurements performed on

circuits not directly connected to MAINS.

NOTE: Examples are measurements on circuits not derived from MAINS, and specially protected (internal) MAINS derived circuits. In the latter case, transient stresses are variable; for that reason, requires that the transient withstand capability of the equipment is made known to the user.

\* When using this Multimeter, the user must observe all normal safety rules concerning:

— Protection against the dangers of electric current.

— Protection of the Multimeter against misuse.

\* For your own safety, only use the test probes supplied with the instrument. Before use, check that they are in good condition.

### **1.1.2 During use**

\* If the meter is used near noise generating equipment, be aware that display may become unstable or indicate large errors.

\* Do not use the meter or test leads if they look damaged.

\* Use the meter only as specified in this manual; otherwise, the protection provided by the meter may be impaired.

\* Use extreme caution when working around bare conductors or bus bars.

\* Do not operate the meter around explosive gas, vapor, or dust.

\* Verify a Meter's operation by measuring a known voltage. Do not use the Meter if it operates abnormally. Protection

may be impaired. When in doubt, have the Meter serviced.

- \* Uses the proper terminals, function, and range for your measurements.

- \* When the range of the value to be measured is unknown, check that the range initially set on the multimeter is the highest possible or, wherever possible, choose the autoranging mode.

- \* To avoid damages to the instrument, do not exceed the maximum limits of the input values shown in the technical specification tables.

- \* **When the multimeter is linked to measurement circuits, do not touch unused terminals.**

- \* Caution when working with voltages above 60Vdc or 30Vac rms. Such voltages pose a shock hazard.

- \* When using the probes, keep your fingers behind the finger guards.

- \* When making connections, connect the common test lead before connecting the live test lead; when disconnecting, disconnect the live test lead before disconnecting the common test lead.









- \* Before changing functions, disconnect the test leads from the circuit under test.

- \* For all dc functions, including manual or auto-ranging, to avoid the risk of shock due to possible improper reading, verify the presence of any ac voltages by first using the ac function. Then select a dc voltage range equal to or greater than the ac range.

- \* Disconnect circuits power and discharge all high-voltage capacitors before testing resistance, continuity, diodes, or capacitance.
- \* Never perform resistance or continuity measurements on live circuits.
- \* Before measuring current, check the meter's fuse and turn off power to the circuit before connecting the meter to the circuit.
- \* In TV repair work, or when carrying out measurements on power switching circuits, remember that high amplitude voltage pulses at the test points can damage the multimeter. Use of a TV filter will attenuate any such pulses.
- \* Use just one 6F22 battery, properly installed in the Meter's battery case, to power the Meter.
- \* Replace the battery as soon as the battery indicator (  ) appears. With a low battery, the Meter might produce false readings that can lead to electric shock and personal injury.
- \* Do not measure voltages above 600V in Category III, or 1000V in Category II installations.
- \* When in REL mode, the “REL” symbol is displayed. Caution must be used because hazardous voltage may be present.
- \* Do not operate the Meter with the case (or part of the case) removed.

### **1.1.3 Symbols:**

Symbols used in this manual and on the instrument:

-  **Caution:** refer to the instruction manual. Incorrect use may result in damage to the device or its components.
-  AC (Alternating Current)
-  DC (Direct Current)
-  AC or DC
-  Earth ground
-  Double insulated
-  Fuse
-  Conforms to European Union directives

#### 1.1.4 Instructions

- \* Remove test leads from the Meter before opening the Meter case or battery cover.
- \* When servicing the Meter, use only specified replacement parts.
- \* Before opening up the instrument, always disconnect from all sources of electric current and make sure you are not charged with static electricity, which may destroy internal components.
- \* Any adjustment, maintenance or repair work carried out on the meter while it is live should be carried out only by appropriately qualified personnel, after having taken into account the instructions in this present manual.
- \* A "qualified person" is someone who is familiar with the installation, construction and operation of the equipment and the hazards involved. He is trained and authorized to

energize and de-energize circuits and equipment in accordance with established practices.

- \* When the instrument is opened up, remember that some internal capacitors can retain a dangerous potential even after the instrument is switched off.

- \* If any faults or abnormalities are observed, take the instrument out of service and ensure that it cannot be used until it has been checked out.

- \* If the meter is not going to be used for a long time, take out the battery and do not store the meter in high temperature or high humidity environment.

## **1.2 Protection mechanisms**

This instrument is fitted with various protection mechanisms:

- \* Varistor protection for limiting transients of over 1000V at the  $V_{\Omega}$  terminal.

- \* A PTC (positive temperature coefficient) resistor protects against permanent overvoltages of up to 1000V during resistance, capacitance, temperature, continuity and diode measurement.

## 2. Description

### 2.1 Instrument

#### Familiarization

- ① LCD display
- ② Keypad
- ③ Rotary switch
- ④ Terminals
- ⑤ Battery cover

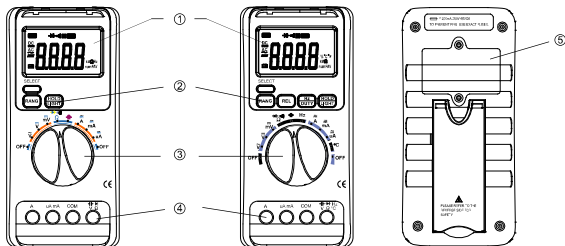

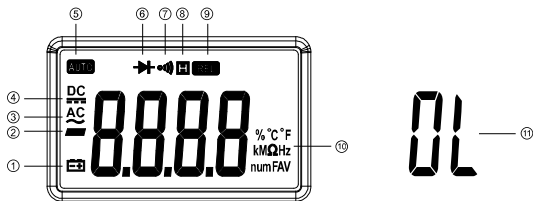

## 2.2 LCD Display



- ① Low battery indication (Note: When this symbol appears, it means that the battery needs to be replaced.)
- ② Indicates negative readings
- ③ Indicator for AC voltage or current
- ④ Indicator for DC voltage or current
- ⑤ The meter is in the Autorange mode in which the meter automatically selects the range with the best resolution.
- ⑥ The meter is in Diode Test mode.
- ⑦ The meter is in Continuity Check mode.
- ⑧ The meter is in Data Hold mode.
- ⑨ The meter is in Relative Measurement mode.
- ⑩ Measurement units
- ⑪ This symbol means that the input is too large for the selected range.

**NOTE:** The model A has no Relative Measurement, Temperature Measurement and Frequency & Duty Cycle measurement functions, so the LCD DISPLAY has no “REL”, “°F”, “°C”, “%” and “Hz” symbols.

### 2.3 Keypad (Note: model A has no “REL” and “Hz/DUTY” keys.)

Key	Function	Operation performed
SELECT	$\Omega$   A mA $\mu$ A <i>Power-up Option</i>	Switches between Resistance measurement, Diode Test and Continuity check. Switches between DC and AC current. <i>Disables automatic power-off feature.</i>
HOLD/ LIGHT	Any switch position	Press it to enter and exit the Data Hold mode. Press it and hold 2 seconds, backlight on; if press it and hold for seconds again, backlight off.
RANGE	V~, V  , $\Omega$ , A, mA and $\mu$ A.	1. Press it to enter the manual ranging mode. 2. Press it to step through the ranges available for the selected function. 3. Press it and hold <b>RANGE</b> for 2 seconds to return to

		autoranging.
<b>REL</b>	<b>Any switch position</b>	Press <b>REL</b> to enter and exit the Relative measurement mode.
<b>Hz/ DUTY</b>	<b>V~, A, mA and <math>\mu</math>A.</b>	Press it to start the frequency counter; press it again to enter duty cycle mode, and press it again to exit the frequency counter mode.

### 3. Function description

#### 3.1 General Functions

##### 3.1.1 DATA HOLD mode

Data Hold mode makes the meter stop updating the display. Enabling Data Hold function in autorange mode makes the meter switch to Manual ranging mode, but the full-scale range remains the same. Data Hold function can be cancelled by changing the measurement mode, pressing **RANGE** key, or push **HOLD/LIGHT** key again.

To enter and exit the Data Hold mode:

1. Press **HOLD/LIGHT** key (short press). Fixes the display on the current value, **H** is displayed.
2. A second short press returns the meter to normal mode.

### 3.1.2 Manual ranging and Autorange mode

The Meter has both manual ranging and autorange options.

\* In the autorange mode, the Meter selects the best range for the input detected. This allows you to switch test points without having to reset the range.

\* In the manual ranging mode, you select the range. This allows you to override autorange and lock the meter in a specific range.

\* The Meter defaults to the autorange mode in measurement functions that have more than one range. When the Meter is in the autorange mode, **AUTO** is displayed.

To enter and exit the manual range mode:

1. Press **RANGE** key. The Meter enters the manual ranging mode. **AUTO** turns off. Each presses of **RANGE** key increments the range. When the highest range is reached, the Meter wraps to the lowest range.

*NOTE: If you manually change the measurement range after entering the Data Hold modes, the Meter exits this mode.*

2. To exit the manual ranging mode, press and hold down **RANGE** key for two seconds. The Meter returns to the autorange mode and **AUTO** is displayed.

### 3.1.3 Battery Saver

The Meter enters the "sleep mode" and blanks the display

if the Meter is on but not used for 30 minutes.

Press the **HOLD /LIGHT** key or rotate the rotary switch to wake the meter up.

To disable the Sleep mode, hold down the **SELECT** key while turning the meter on.

### **3.1.4 Relative measurement mode (Only model B)**

The Meter will display relative measurement in all functions except frequency.

To enter and exit the relative measurement mode:

1. With the Meter in the desired function, touch the test leads to the circuit on which you want future measurement to be based.
2. Press **REL** key to store the measured value and activate the relative measurement mode. The difference between the reference value and subsequent reading is displayed.
3. Press **REL** key for more than 2 seconds to return the Meter to normal operation.

## 3.2 Measurement Functions

### 3.2.1 AC and DC Voltage measurement



***To avoid electrical shock and/or damage to the instrument, do not attempt to take any voltage measurement that might exceeds 1000Vdc or 700Vac rms.***

***To avoid electrical shock and/or damage to the instrument, do not apply more than 1000Vdc or 700Vac rms between the common terminal and the earth ground.***

The Meter's voltage ranges are 400.0mV, 4.000V, 40.00V, 400.0V and 1000V/700V (AC) .

To measure ac or dc voltage (set up and connect the Meter as shown in Figure 2):

1. Set rotary switch to the DCV, ACV or DCmV range.
2. Connect the black and red test leads to the COM and V terminals respectively.
3. Connect the test leads to the circuit being measured
4. Read the displayed value. The polarity of red test lead connection will be indicated when making a DCV measurement.

#### **NOTE:**

Unstable display may occur especially at 400mV range, even though you do not put test leads into input terminals, in this case, if an erroneous reading is suspected, short the V terminal and the COM terminal,

and make sure the zero display.

For better accuracy when measuring the dc offset of an ac voltage, measure the ac voltage first. Note the ac voltage range, then manually select a dc voltage range equal to or higher than the ac range. This improves the accuracy of the dc measurement by ensuring that the input protection circuits are not activated.



### 3.2.2 Resistance measurement



***To avoid electrical shock and/or damage to the instrument, disconnect circuit power and discharge all high-voltage capacitors before measuring resistance.***

The Meter's resistance ranges are 400.0 $\Omega$ , 4.000k $\Omega$ , 40.00k $\Omega$ , 400.0k $\Omega$ , 4.000M $\Omega$  and 40.00M $\Omega$ .

To measure resistance (set up the Meter as shown in figure 3):

1. Set the rotary switch to  $\Omega$    range.
2. Connect the black and red test leads to the COM and V $\Omega$  terminals respectively.
3. Connect the test leads to the circuit being measured and read the displayed value.

Some tips for measuring resistance:

The measured value of a resistor in a circuit is often different from the resistor's rated value. This is because the Meter's test current flows through all possible paths

between the probe tips.

In order to ensure the best accuracy in measurement of low resistance, short the test leads before measurement and memory the test probe resistance in mind. This necessary to subtract for the resistance of the test leads.

The resistance function can produce enough voltage to forward-bias silicon diode or transistor junctions, causing them to conduct. To avoid this, do not use the 40M $\Omega$  range for in-circuit resistance measurements.

On 40M $\Omega$  range, the meter may take a few seconds to stabilize reading. This is normal for high resistance measuring.



When the input is not connected, i.e. at open circuit, the figure "OL" will be displayed for the overrange condition.

### 3.2.3 Diode Test



***To avoid electrical shock and/or damage to the instrument, disconnect circuit power and discharge all high-voltage capacitors before testing diodes.***

To test a diode out of a circuit (set up the Meter as shown in Figure 4):

1. Set the rotary switch to  $\Omega$    range.
2. Press the SELECT key once to activate Diode Test.
3. Connect the black and red test leads to the COM and V $\Omega$  terminals respectively.
4. For forward-bias readings on any semiconductor

component, place the red test lead on the component's anode and place the black test lead on the component's cathode.

5. The meter will show the approx. forward voltage of the diode.



In a circuit, a good diode should still produce a forward bias reading of 0.5V to 0.8V; however, the reverse-bias reading can vary depending on the resistance of other pathways between the probe tips.

### 3.2.4 Continuity Check



***To avoid electrical shock and/or damage to the instrument, disconnect circuit power and discharge all high-voltage capacitors before testing for Continuity.***

To test for continuity:

1. Set the rotary switch to  $\Omega$    range.
2. Press the SELECT key twice to activate Continuity Check.
3. Connect the black and red test leads to the COM and  $\Omega$  terminals respectively.
4. Connect the test leads to the resistance in the circuit being measured.
5. When the test lead to the circuit is below  $75\Omega$ , a continuous beeping will indicate it.

**Note:**

Continuity test is available to check open/short of the circuit.

**3.2.5 Capacitance measurement**

***To avoid electrical shock and/or damage to the instrument, disconnect circuit power and discharge all high-voltage capacitors before measuring capacitance. Use the dc voltage function to confirm that the capacitor is discharged.***

The Meter's capacitance ranges are 50.00nF, 500.0nF, 5.000 $\mu$ F, 50.00 $\mu$ F and 100.0 $\mu$ F.

To measure capacitance:

1. Set the rotary switch to **⇄** range.
2. Connect the black and red test leads to the COM and **⇄** terminals respectively (or you can use capacitor test lead).
3. Connect the test leads to the capacitor being measured and read the displayed value.

**Some tips for measuring capacitance:**

The meter may take a few seconds to stabilize reading. This is normal for high capacitance measuring.

To improve the accuracy of measurements less than 50nF, subtract the residual capacitance of the Meter and leads.

Below 500pF, the accuracy of measurements is

unspecified.

### 3.2.6 Frequency and Duty Cycle measurement (Only model B)



***Do not measure Frequency on high voltage (>700V) to avoid electrical shock hazard and/or damage to the instrument.***

The Meter can measure Frequency or Duty Cycle while making either an AC Voltage or AC Current measurement.

To measure frequency or Duty Cycle:

1. With the meter in the desired function (AC Voltage or AC Current), press the **Hz %** key.
2. Read the frequency of the AC signal on the display.
3. To make a duty cycle measurement, press the **Hz %** key again.
4. Read the percent of duty cycle on the display.
5. Set the rotary switch to the Hz range.
6. Insert the black and red test leads into the COM and Hz input terminals.
7. Connect the test leads tip in parallel with the circuit to be measured. And don't touch any electrical conductors.
8. At frequency measuring status, press **Hz %** one time then meter enters duty cycle measuring status, press it again then return to frequency measuring status.
9. Read the result directly from the display.

**Note:**

In noisy environment, it is preferable to use shield cable for measuring small signal.

**3.2.7 Temperature measurement (Only model B)**

*To avoid electrical shock and/or damage to the instrument, do not apply more than 250Vdc or 250Vac rms between the °C terminal and the COM terminal.*

*To avoid electrical shock, do not use this instrument when voltages at the measurement surface exceed 60v dc or 24v rms. Ac.*

*To avoid damage or burns. Do not make temperature measurement in microwave ovens.*

To measure temperature:

1. Set the rotary switch to °C range and the LCD will show the current environment temperature.
2. Insert 'K' type thermocouples into the COM terminal and °C terminal (or you can insert it by using Multi Function Socket), Takings care to observe the correct polarity.
3. Touch the object with the thermocouple probe for measurement.
4. Read the stable reading from LCD

**3.2.8 Current measurement**



***To avoid damage to the Meter or injury if the fuse blows, never attempt an in-circuit current measurement where the open-circuit potential to earth is greater than 250V.***

***To avoid damage to the meter, check the meter's fuse before proceeding. Use the proper terminals, function, and range for your measurement. Never place the probes in parallel with a circuit or component when the leads are plugged into the current terminals.***

The Meter's current ranges are 400.0 $\mu$ A, 4000 $\mu$ A, 40.00mA, 400.0mA, 4.000A and 10.00A.

To measure current (set up the Meter as shown in Figure 7):

1. Turn off power to the circuit. Discharge all high voltage capacitors.
2. Set the rotary switch to the  $\mu$ A, mA or A range.
3. Press the SELECT key to select DCA or ACA measuring mode.
4. Connect the black test lead to the COM terminal and the red test leads to the mA terminal for a maximum of 400mA. For a maximum of 10A, move the red test lead to the A terminal.
5. Break the circuit path to be tested.

Touch the black probe to the more negative side of the break; touch the red probe to the more positive side of

- the break. (Reversing the leads will give a negative reading, but will not damage the Meter.)
6. Turn on power to the circuit; then read the display. Be sure to note the measurement units at the right side of the display ( $\mu\text{A}$ , mA or A). When only the figure "OL" displayed, it indicates overrange situation and the higher range has to be selected.
  7. Turn off power to the circuit and discharge all high voltage capacitors. Remove the Meter and restore the circuit to normal operation.

## **4 Technical specifications**

### **4.1 GENERAL SPECIFICATIONS**

Environment conditions:

1000V CAT. II and 600V CAT. III

Pollution degree: 2

Altitude < 2000m

Operating temperature: 0~40°C, 32°F~104°F(<80% RH,  
<10°C non-condensing)

Storage temperature: -10~60 °C, 14°F~140°F(<80% RH,  
battery removed)

Temperature Coefficient:  $0.1 \times (\text{specified accuracy}) / ^\circ\text{C}$   
(<18°C or >28°C)

MAX. Voltage between terminals and earth ground: 700V  
AC rms or 1000V DC.

Fuse Protection:  $\mu$ A and mA: F 500mA/600V  $\varnothing$ 5 $\times$ 20; A: F 10A/600V  $\varnothing$ 6.3 $\times$ 32.

Sample Rate: 3 times/sec for digital data.

Display: 3 3/4 digits LCD display. Automatic indication of functions and symbols.

Range selection: automatic and manual.

Over Range indication: LCD will display "OL".

Low battery indication: The "" is displayed when the battery is under the proper operation range.

Polarity indication: "-" displayed automatically.

Power source: 9V

Battery type: 6F22.

Dimensions: 180(L) $\times$ 85(W) $\times$ 45(H) mm.

Weight: 360g. Approx. (battery included).

## 4.2 Measurement specifications

Accuracy is specified for one year after calibration, at operating temperatures of 18°C to 28°C, with relative humidity at 0% to 75%.

Accuracy specifications take the form of:  $\pm$  (% of Reading + Number of Least Significant Digits)

### 4.2.1 Voltage

Function	Range	Resolution	Accuracy
DC Millivolt. <b>mV<math>\overline{=}</math></b>	400mV	0.1mV	$\pm(1.0\%$ of rdg +10 digits)
DC Voltage <b>V<math>\overline{=}</math></b>	4V	1mV	$\pm(0.5\%$ of rdg +3 digits)
	40V	10mV	
	400V	100mV	
	1000V	1V	
AC Voltage <sup>1, 2</sup> <b>V<math>\sim</math></b>	400mV <sub>3</sub>	0.1mV	$\pm(3.0\%$ of rdg + 3 digits)
	4V	1mV	$\pm(1.0\%$ of rdg + 3 digits)
	40V	10mV	
	400V	100mV	
	700V	1V	$\pm(1.2\%$ of rdg + 3 digits)

1. Frequency Range for ACV: 40Hz~400Hz. 2. Response for ACV: Average, calibrated in rms of sine wave. 3. Manual Range only  
 Overload Protection: 1000V dc or 700V ac rms.  
 Input Impedance (Nominal): DC voltage:  $>10M\Omega$   $<100pF$ ; AC voltage:  $>5M\Omega$   $<100pF$   
 Common Mode Rejection Ratio: DC voltage:  $>100dB$  at dc, 50 or 60 Hz; AC voltage:  $>60dB$  at dc, 50 or 60 Hz  
 Normal Mode Rejection Ratio: DC voltage:  $>45dB$  at 50 or 60Hz

#### 4.2.2 Frequency (Only model B)

Function	Range	Resolution	Accuracy
Frequency Hz (10Hz-100kHz)	50.00Hz	0.01 Hz	±(0.1% of rdg +3digits)
	500.0Hz	0.1 Hz	
	5.000kHz	0.001kHz	
	50kHz	0.01kHz	
	100kHz	0.1kHz	

Overload protection:250V dc or 250V ac rms

#### 4.2.3 Resistance

Function	Range	Resolution	Accuracy
Resistance $\Omega$	400.0 $\Omega$	0.1 $\Omega$	±(0.5% of rdg+3 digits)
	4.000k $\Omega$	1 $\Omega$	±(0.5% of rdg+2 digits)
	40.00k $\Omega$	10 $\Omega$	
	400.0k $\Omega$	100 $\Omega$	
	4.000M $\Omega$	1k $\Omega$	
	40.00M $\Omega$	10k $\Omega$	±(1.5% of rdg+3 digits)

Overload protection:250V dc or 250V ac rms

#### 4.2.4 Diode Test

Function	Range	Resolution	Accuracy
Diode Test 	1 V	0.001V	1.0% uncertainty

Test Condition: Forward DC current approximately 1mA.

Reversed DC voltage approximately 1.5V.

Overload protection:250V dc or 250V ac rms

#### 4.2.5 Continuity Check

Function	Range	Resolution	Test Condition
	400 $\Omega$	0.1 $\Omega$	Open circuit voltage: approx. 0.5V

Description: Continuity beeper $\leq 75\Omega$

Overload protection:250V dc or 250V ac rms

#### 4.2.6 Temperature (Only model B)

Function	Range	Resolution	Accuracy
Celsius scale $^{\circ}\text{C}$	-55 $^{\circ}\text{C}$ ~0 $^{\circ}\text{C}$	$\odot 0.1^{\circ}\text{C}$	$\pm(9.0\%$ of rdg + 2 $^{\circ}\text{C}$ )
	1 $^{\circ}\text{C}$ ~400 $^{\circ}\text{C}$		$\pm(2.0\%$ of rdg+3 $^{\circ}\text{C}$ )
	401 $^{\circ}\text{C}$ ~1000 $^{\circ}\text{C}$	1 $^{\circ}\text{C}$	$\pm 2.0\%$ of rdg

Temperature specifications do not include thermocouple errors.

Overload protection:250V dc or 250V ac rms

#### 4.2.7 Capacitance

Function	Range	Resolution	Accuracy
Capacitance 	50nF	10pF	<10nF:±[5.0 % of (rdg+50 digits) ±(3.0% of rdg+10 digits)
	500nF	100pF	± (3.0% of rdg+5 digits)
	5µF	1nF	
	50µF	10nF	
	100µF	100nF	

Overload protection:250V dc or 250V ac rms

#### 4.2.8 Current

Function	Range	Resolution	Accuracy
DC µA	400µA	0.1µA	±(1.5% of rdg+3 digits)
	4000µA	1µA	
DC mA	40mA	0.01mA	±(1.5% of rdg+3 digits)
	400mA	0.1mA	
DC A	4A	1mA	±(2.0% of rdg+8 digits)
	10A	10mA	
AC µA	400µA	0.1µA	±(1.8% of rdg+5 digits)
	4000µA	1µA	
AC mA	40mA	0.01mA	±(1.8% of rdg+5 digits)
	400mA	0.1mA	
AC A	4A	1mA	±(3.0% of rdg+10 digits)
	10A	10mA	

1. Frequency Range: 40Hz-200Hz
  2. Response: Average, calibrated in rms of sine wave
- Overload protection: F 10A/600V fuse for A range. F 500mA/600V fuse for  $\mu$ A and mA ranges.
- Maximum input current: 400mA dc or 400mA ac rms for  $\mu$ A and mA ranges, 10A dc or 10A ac rms for A ranges.
- For measurements >5A, 4 minutes maximum ON to measure 10 minutes OFF; Above 10A unspecified.

## 5. Maintenance

This section provides basic maintenance information, including fuse and battery replacement instructions. Do not attempt to repair or service your Meter unless you are qualified to do so and have the relevant calibration, performance test, and service information.

### 5.1 General Maintenance



***To avoid electrical shock or damage to the meter, do not get water inside the case. Remove the test leads and any input signals before opening the case***

Periodically wipe the case with a damp cloth and mild detergent. Do not use abrasives or solvents. Dirt or moisture in the terminals can affect readings.

To clean the terminals:

Turn the meter off and remove all test leads.

Shake out any dirt that may be in the terminals.

Soak a new swab with a cleaning and oiling agent (such as WD-40).

Work the swab around in each terminal. The oiling agent insulates the terminals from moisture-related contamination.

## 5.2 Fuse replacement



***Before replacing the fuse, disconnect test leads and/or any connectors from any circuit under test. To prevent damage or injury, replace the fuse only with specified ratings.***

To replace the Meter's fuse:

1. Set rotary switch to the OFF position.
2. Disconnect test leads and/or any connectors from the terminals.
3. Use a screwdriver to unlock the four screws on the rear cover.
4. Take out the rear cover from the meter.
5. Remove the fuse by gently prying one end loose, then sliding the fuse out of its bracket.
6. Install the replacement fuses only with specified ratings: F 10A/600V  $\varnothing$ 6.3 $\times$ 32 and F 500mA/600V  $\varnothing$ 5 $\times$ 20
7. Rejoin the rear cover and tighten the screws.

### 5.3 Battery replacement



***To avoid false readings, which could lead to possible electric shock or personal injury, replace the battery as soon as the battery indicator (  ) appears.***

***Before replacing the battery, disconnect test leads and/or any connectors from any circuit under test, turn the meter off and remove test leads from the input terminals.***

To replace the battery:

1. Set rotary switch to the OFF position.
2. Disconnect test leads and/or any connectors from the terminals.
3. Use a screwdriver to unlock the two screws on the battery cover.
4. Take out the battery cover from the meter.
5. Remove the used battery.
6. Replace with one new 9V battery (6F22).
7. Rejoin the battery cover and tighten the screws.