

OPERATOR'S INSTRUCTION MANUAL

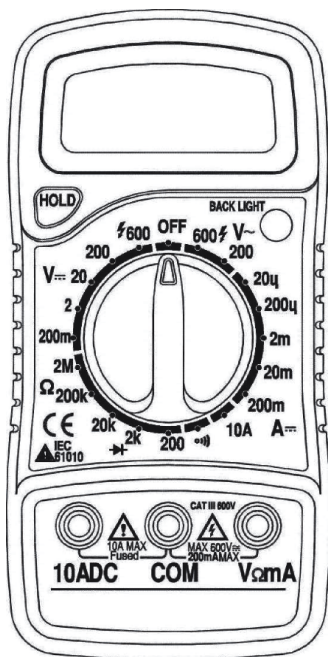

DIGITAL MULTIMETER

DURING USE

- Never exceed the protection limit values indicated in specifications for each range of measurement.
- When the meter is linked to measurement circuit, do not touch unused terminals.
- Never use the meter to measure voltages that might exceed 600V above earth ground in category III installations.
- When the value scale to be measured is unknown beforehand, set the range selector at the highest position.
- Before rotating the range selector to change functions, disconnect test leads from the circuit under test.
- When carrying out measurements on TV or switching power circuits always remember that there may be high amplitude voltages pulses at test points, which can damage the meter.
- Always is careful when working with voltages above 60V dc or 30V ac rms. Keep fingers behind the probe barriers while measuring.
- Never perform resistance measurements on live circuits.

GENERAL DESCRIPTION

The meter is a handheld 3 1/2 digital multimeter for measuring DC and AC voltage, DC current, Resistance, Diode, Continuity Test with battery operated.
The Back light of display is optional.

SAFETY INFORMATION

This multimeter has been designed according to IEC61010 concerning electronic measuring instruments with an overvoltage category (CAT III 600V) and pollution 2.
Follow all safety and operating instructions to ensure that the meter is used safely and is kept in good operating condition.
Full compliance with safety standards can be guaranteed only with test leads supplied. If necessary, they must be replaced with the type specified in this manual.

SAFETY SYMBOLS

- ⚠ Important safety information, refer to the operating manual.
- ⚡ Dangerous voltage may be present.
- ⏚ Earth ground.
- Double insulation (Protection class II).
- ⚡ Fuse must be replaced with rating specified in the manual.

MAINTENANCE

- Before opening the case, always disconnect test leads from all energized circuits.
- For continue protection against fire; replace fuse only with the specified voltage and current ratings:
F 250mA/600V(Quick Acting) F 10A/600V(Quick Acting)
- Never use the meter unless the back cover is in place and fastened completely.
- Do not use abrasives or solvents on the meter. To clean it using a damp cloth and mild detergent only.

FRONT PANEL

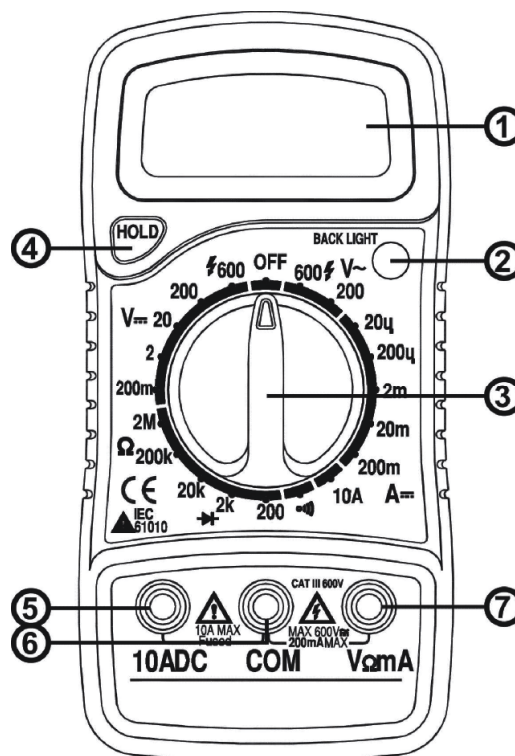

FRONT PANEL DESCRIPTION

- ① Display
3 1/2 digit, 7 segment, 15mm high LCD.
- ② Back light (option)
When this button is pushed, the Back light of display is on. After about 5 seconds, the Back light is self-off. The Back light is on again, just push this button once.
- ③ Rotary switch
This switch is used to select functions and desired ranges as well as to turn on/off the meter.
- ④ Hold button
When this button is pushed, the display will keep the last reading and "H" symbol will appear on the LCD until pushing it again.
- ⑤ "10A" jack
Plug in connector for red test lead for 10A measurement.
- ⑥ "COM" jack
Plug in connector for black (negative) test lead.
- ⑦ "V.Ω.mA" jack Plug in connector for red (positive) test lead for voltage, resistance and current (except 10A) measurements.

SPECIFICATIONS

Accuracy is specified for a period of one year after calibration and at 18 to 28°C (64°F to 82°F) with relative humidity to 80%.

GENERAL

Maximum voltage between terminals and earth ground	:CAT III 600V
Fuse protection	:F 250mA/600V /F 10A/600V
Power	:9V battery, NEDA 1604 or 6F22
Display	: LCD, 1999 counts, updates 2-3/sec.
Measuring method	:Dual-slope integration A/D converter
Overrange Indication	:Only figure "1" on the display
Polarity indication	: "-" displayed for negative polarity
Operating Environment	:0 to 40°C
Storage temperature	:-10°C to 50°C.
Low battery indication	: "  " appears on the display
Size	:138mm × 69mm × 31mm
Weight	: Approx.170g.

-4-

Maximum Open Circuit Voltage: 3.2V

Overload Protection: 250V dc or rms. ac for all ranges.

OPERATING INSTRUCTIONS

DC VOLTAGE MEASUREMENT

1. Connect the red test lead to the "V.Ω.mA" jack and the black lead to the "COM" jack.
2. Set rotary switch at desired DCV position. If the voltage to be measured is not known beforehand, set range switch at the highest range position and then reduce it until satisfactory resolution is obtained.
3. Connect test leads across the source or load being measured.
4. Read voltage value on the LCD display along with the polarity of the red lead connection.

DC CURRENT MEASUREMENT

1. Connect the red test lead to the "V.Ω.mA" jack and the black test lead to "COM" jack. (For measurements between 200mA and 10A, remove red lead to "10A" jack.)
2. Set the rotary switch at desired DCA position.
3. Open the circuit in which the current is to be measured, and connect test leads in series with the circuit.
4. Read current value on LCD display along with the polarity of red lead connection.
 - 10A range measurement 15second each 10minute.

AC VOLTAGE MEASUREMENT

1. Connect the red test lead to "V.Ω. mA" jack and the black test lead to the "COM" jack.
2. Set the rotary switch at desired ACV position.
3. Connect test leads across the source or load being measured.
4. Read voltage value on the LCD display.

RESIS TANCE MEASUREMENT

1. Connect the red test lead to "V. Ω. mA" jack and black test lead to the "COM" jack. (The polarity of red lead is positive "+".)
2. Set the rotary switch at desired "Ω" range position.
3. Connect test leads across the resistor to be measured and read LCD display.
4. If the resistance being measured is connected to a circuit, turn off power and discharge all capacitors before applying test probes.

-6-

DC VOLTAGE

Range	Resolution	Accuracy
200mV	100μV	±0.5% of rdg ± 2 digits
2V	1mV	±0.5% of rdg ± 2 digits
20V	10mV	±0.5% of rdg ± 2 digits
200V	100mV	±0.5% of rdg ± 2 digits
600V	1V	±0.8% of rdg ± 2 digits

Overload Protection: 250V rms. For 200mV range 600V dc or rms. ac for other ranges.

DC CURRENT

Range	Resolution	Accuracy
20μA	0.01μA	±1% of rdg ± 2 digits
200μA	0.1μA	±1% of rdg ± 2 digits
2mA	1μA	±1% of rdg ± 2 digits
20mA	10μA	±1% of rdg ± 2 digits
200mA	100μA	±1.5% of rdg ± 2 digits
10A	10mA	±3% of rdg ± 2 digits

Overload Protection: F 250mA/600V fuse for uA mA range F 10A/600V fuse for 10A range

● 10A range measurement 15second each 10minute.

AC VOLTAGE

Range	Resolution	Accuracy
200V	100mV	±1.2 % of rdg ± 10 digits
600V	1V	±1.2 % of rdg ± 10 digits

Overload Protection: 600V dc or rms. ac for all ranges.Frequency range: 40Hz to 400Hz.

Response: Average responding, calibrated in rms. of a sine wave.

DIODE & CONTINUITY

Range	Description
•	If continuity exists (about less than 40Ω), built-in buzzer will sound.
➔	Show the approx. forward voltage drop of the diode.

Overload Protection: 250V dc or rms. ac.

RESISTANCE

Range	Resolution	Accuracy
200Ω	0.1Ω	±0.8% of rdg ± 3 digits
2kΩ	1Ω	±0.8% of rdg ± 2 digits
20kΩ	10Ω	±0.8% of rdg ± 2 digits
200kΩ	100Ω	±0.8% of rdg ± 2 digits
2MΩ	1kΩ	±1.0% of rdg ± 2 digits

-5-

DIODE TEST

1. Connect the red test lead to "V.Ω.mA" jack and the black test lead to the "COM" jack (The polarity of red lead is positive "+").
2. Set the rotary switch at "➔" position.
3. Connect the red test lead to the anode of the diode to be tested and the black test lead to the cathode of the diode.The approx. forward voltage drop of the diode will be displayed. If the connection is reversed, only figure "1" will be shown.

AUDIBLE CONTINUITY TEST

1. Connect red test lead to "V.Ω.mA", black test lead to "COM".
2. Set range switch to "•||" position.
3. Connect test leads to two points of circuit to be tested. If continuity exists, built-in buzzer will sound.

BATTERY & FUSE REPLACEMENT

If "  " appears on display, it indicates that the battery should be replaced.

Fuse rarely need replacement and blow almost always as a result of operator's error.

To replace battery & fuse (250mA/600V or 10A/600V) remove the 2 screws in the bottom of the case. Simply remove the old, and replace with a new one.

Be careful to observe battery polarity.



WARNING

Before attempting to open the case, always be sure that test leads have been disconnected from measurement circuits. Close case and tighten screws completely before using the meter to avoid electrical shock hazard.

ACCESSORIES

- Operator's instruction manual
- Set of test leads
- Gift box
- Temperature sensor
- 9 volt battery. NEDA 1604 6F22 006P type
- Holster (option)

-7-