

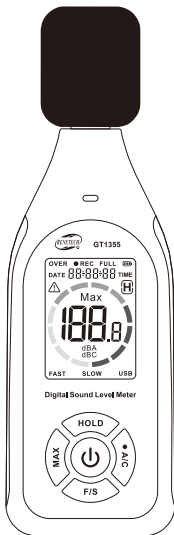

MODEL: GT1355

Sound Level Meter Instruction Manual



Contents

I. Product introduction

A. Introduce.....	1
B. Features.....	1
C. Component names.....	2
D. Specifications.....	3
E. Calibration.....	4

II. Operation instructions

A. Power on/off.....	5
B. Data HOLD.....	5
C. DATE/TIME.....	6
D. Maximum mode.....	6
E. High/low alarm value.....	7
F. A/C Frequency weighting selection.....	8
G. F/S Time weighting selection.....	8
H. Data record.....	9
I. Delete record.....	9

III. PC software

A. Requirements of computer configuration.....	10
B. Software download.....	10
C. Connection status.....	11
D. Software instruction.....	11

IV. Other

A. Attentions.....	16
B. Maintenance.....	16

I. Product introduction

A. Introduce

This Sound Level Meter has been designed to meet the measurement requirement of noise engineers, noise quality control and health prevention in various environments, such as noise measurement in factory, office, traffic road, family and all other noise measurement applications.

B. Features

1. Real-time measurement of various environmental noises
2. A/C Frequency weighting selection
3. Fast/Slow Time weighting selection
4. Three-color light alarm
5. Maximum
6. Data HOLD
7. Data storage: 31,000 data record function
8. Data Read(only on PC) and Delete
9. Automatic shutdown for about 10 minutes without button operation
10. Display date and time
11. USB charging and PC communication: Connect with the PC through USB, provides data record download, real-time data sampling analysis, and printing graph&data functions.
12. This Sound Level Meter was designed according to following standards:
 - a. International electrician committee standard:IEC PUB 651 TYPE2
 - b. US national standard: ANSI S1.4 TYPE2

C. Component name

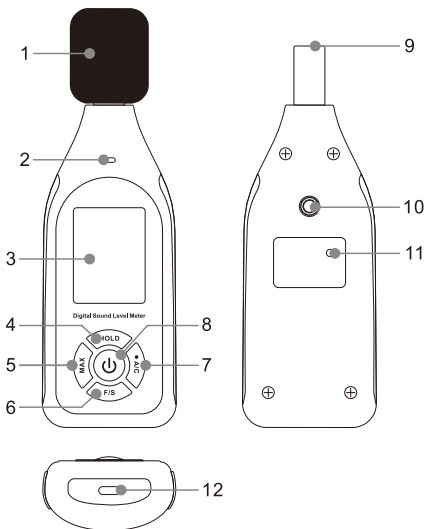

1. Sponge ball (when outdoor use please put on, prevent wind blowing noise disturbing the unit reading)

2. Alarm light

3. LCD display

4. HOLD button

5. MAX button

6. F/S button

7. A/C button

8. Power button

9. Capacitance microphone

10. Tripod fixed screw aperture

11. Calibration knob

12. Type-C interface

D. Specifications

Calibration sound source	94dB@1KHz
Measurement range	30~130 dB(A), 35~130dB(C)
Accuracy	±1.5dB(Reference sound pressure standard,94dB@1KHz)
Resolution	0.1dB
Frequency weighting	A/C
Frequency response	31.5Hz~8500Hz
Time weighting	FAST/SLOW
Sampling rate	FAST: 8 times/second SLOW: 1 times/second
Rated current	70mA
Standby current	5uA
Power supply	3.7V lithium battery /1000mAh
Charging time	1.5h
Duration of service	8h
Data storage	31,000
Microphone	1/2-inch polarization capacitance microphone
Operating temperature	0~50°C
Operating humidity	10~80%RH
Dimension	160*56*31mm(Excluding sponge ball)
Weight	Approx 126g(Excluding sponge ball)

E. Calibration

1. Please use 94dB@1KHZ standard calibration instrument
2. Setting on sound level meter: Frequency weighting is A, Time weighting is FAST
3. Insert the microphone carefully into a 1/2-inch hole in the standard audio source (94dB@1KHz).
4. Turn on the power switch of the standard sound source, adjust the potentiometer at the circular hole in the battery door with slotted screwdriver, and make the LCD display 94.0

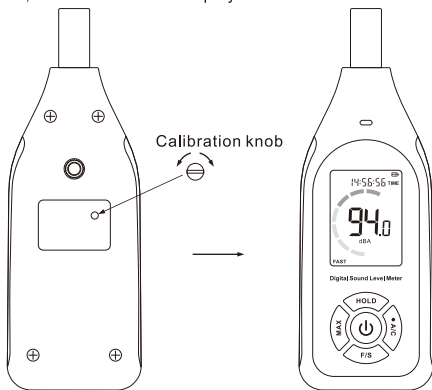

Note:

Our products are all well calibrated before Shipment.

Recommended recalibration cycle: 1 year.

II. Operation instructions

A. Power on/off

1. Power on:

When shutting down, short press the power button to turn on the device. After about 1~2 second of full screen display, the real-time measurement interface will be displayed;

2. Shutdown:

Power on status, long press or short press the power button to shutdown;

3. Automatic shutdown:

Automatic shutdown for about 10 minutes without button operation;

4. Cancel automatic shutdown:

When shutting down, long press the power button to turn on the device. After full screen display, if [UOF] is displayed, the automatic shutdown will be cancelled (only valid for this startup, default automatic shutdown for next startup, need to be cancelled again).

B. Data HOLD

On the measurement interface, short press the HOLD button to display [H] data lock; Short press the HOLD button again to release the data, [H] disappears, and continue measuring.

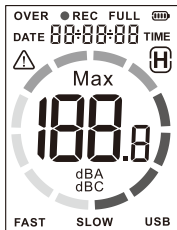

Full Screen Display



Cancel
Automatic Shutdown

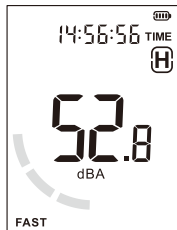

Data HOLD

C. DATE/TIME

1. Date/Time setting:

Long press the Hold button to enter the DATE/TIME setting mode. Short press the A/C button to switch between year - month - day - hour - minute - second - exit setting mode successively (short press the MAX button to switch in reverse order between second - minute - ... - year - exit setting), the value blinks when selected. Short press the HOLD button or F/S button to increase or decrease the value. Long press the HOLD button or F/S button to increase or decrease the value;

2. DATE/TIME display switch:

Long press the F/S button to switch the DATE/TIME display.



DATE Setting



TIME Setting

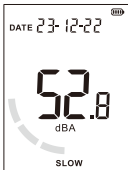

DATE Display



TIME Display

D. Maximum mode

1. On the measurement screen, short press the MAX button to enter the maximum measurement mode. The screen will display [MAX].

2. Maximum mode: The value will be the maximum noise value after entering the mode. The value will not be updated until the measured noise value is larger. Short press the MAX button again to return to the real-time measurement interface (the screen does not display [MAX]).

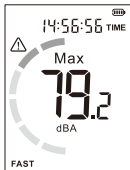

Maximum mode

E. High/low alarm value

1. High/low alarm value setting:

Long press MAX button to enter alarm value setting, then the screen will display []. Short press MAX button to switch high/low alarm value setting. Short press HOLD button or F/S button to increase or decrease alarm value. Long press HOLD button or F/S button to fast increase or decrease alarm value. Long press the MAX button again to exit the alarm setting.

High alarm: [MAX] will be displayed, and indicator light will be red;

Low alarm: [MAX] will not be displayed, and the indicator light will be yellow.

2. Measurement display:

High alarm: When the noise value is greater than or equal to the high alarm value, the screen will display [], and the red light will be on (if the indicator function is off, it will not be on);

Low alarm: When the noise value is greater than or equal to the low alarm value, the screen will display [], and the yellow light will be on (if the indicator function is off, it will not be on);

3. Indicator light on/off:

After entering the alarm value setting, press the A/C button to turn on/off the indicator. Pay attention to the change of the indicator on the panel. If the indicator is on, it means on; if it is off, it means off.



High alarm value setting

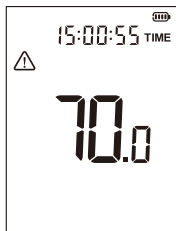

Low alarm value setting

F. A/C Frequency weighting selection

On the measurement interface, short press the A/C button to switch between A (dBA)/C (dBC) weighting

A-Weighting for general sound level measurements.

C-Weighting for checking the low-frequency content of sounds.

G. F/S Time weighting selection

On the measurement interface, short press the F/S button to switch between FAST/ SLOW

FAST is to pick up the current reading;

SLOW is to pick up the reading of average within 1 second.



C (dBC)
FAST

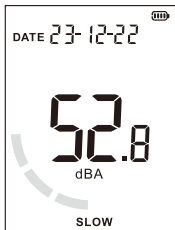

A (dBA)
SLOW

H. Data record

1. Enter the recording mode:

After startup, long press the A/C button to enter the recording mode setting, and the screen will display [REC];

2. Record interval setting:

After entering this mode, press the HOLD button or F/S button to set the record interval time (unit: second), and long press the button to fast increase or decrease; The value ranges from 1 to 99 seconds.

3. Short press the A/C button to start recording data. The screen displays [REC] and blinks [●]. Long press the A/C button again to exit the recording mode.

4. When recording, it will not automatically shut down, long press the power button to shut down.

I. Delete record

Enter the MAX mode (screen will display [MAX]), long press the A/C button until the screen displays [CLR], and return to the measurement interface. At this time, no [MAX] is displayed, and record deletion is complete.

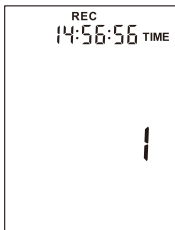

Data record setting



Start recording



Delete records

III. PC software

A. Requirements of computer configuration

1. CPU: Pentium III 600MHZ or above
2. One free available USB connecting interface
3. The lowest screen resolution of monitor is 800*600 (or much higher), true color
4. At least 8MB available memory
5. At least 50MB available disk memory
6. Operation system: Windows 10.

B. Software download

Enter the website "www.benetechno.net" in the browser, press enter and enter the page to find the menu "Support"->"Download Catalog". Click into the page to find the software installation package "SoundLab.zip". Click the download button to directly extract the "zip package" after downloading. Double click on "SoundLabSetup.exe" to install.

C. Connection status

1. Connected to device:

"Connected" appears in the bottom left corner of the PC;

"USB" appears on the lower right corner of the product screen.

2. Disconnected to device:

"Disconnected" is displayed in the bottom left corner of the PC;

"USB" is not displayed on the lower right corner of the product screen.

Connected

PC

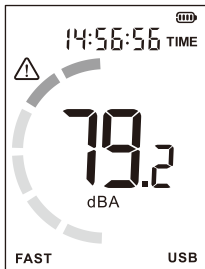

Product screen





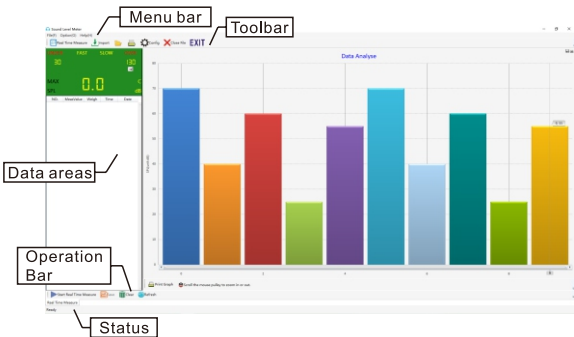

D. Software instruction

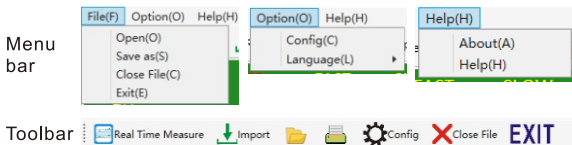
1. Software window:



2. Menu bar/Toolbar:



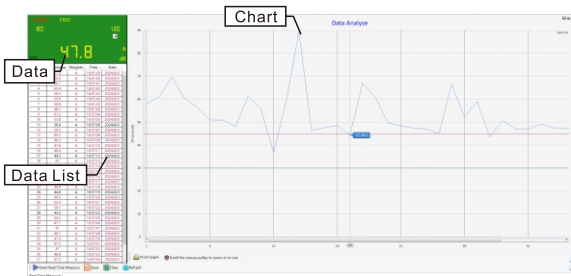

Menu bar	Toolbar	Function
Open		Open a stored .xls measurement data file
Save as	-	Save real-time measurement data as a separate .xls file
Close File		Close the current page
Exit	EXIT	Exit PC software
Config		Setting instrument and software related parameters
Language	-	English, Simplified, Traditional Chinese, Japanese
About	-	Software version description
Help	-	Software problem feedback
-		Real-time data measurement
-		Import the measurement data saved by the product into PC software
-		Print data sheet

3. Data areas:



1) Data:

- Display current data or real-time measurement of the last data;
- Frequency/range/unit and other parameters are updated synchronously with product Settings;
- Click  to display the current noise value in full screen. Click  to exit the full screen.

2) Data list:

- Display detailed parameters of all measurement data;
- Black: does not exceed the alarm value; Red: exceeds the high alarm value; Green: below the low alarm value;

3) Chart:

- Horizontal coordinate: data serial number; Ordinate: Noise value;
- When the mouse moves to the chart, the data is displayed: serial number, noise value;
- Scroll the mouse to zoom the polyline, at this time, "back" and "full display" appear on the top right, click back to the previous step change, full display will display the zoom to display all data;
- Charts can be saved/printed on the top right.

4. System Config: Setting instrument and software related parameters.

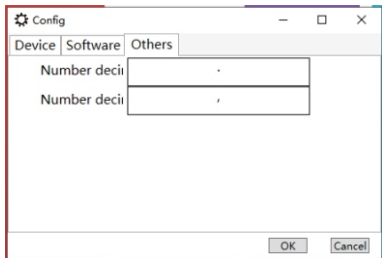
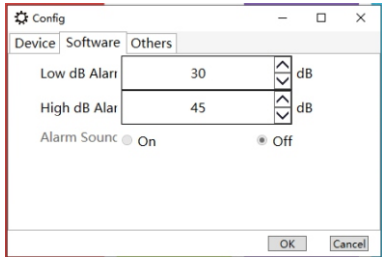
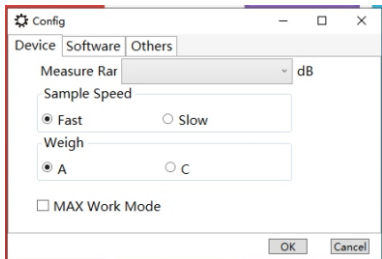

5. Real Time Measure

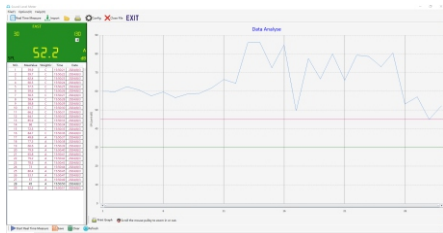

Operation Bar	Function
Start Real Time Measure	Click to start Real Time Measure
Stop Real Time Measure	Click to stop Real Time Measure
Save	Storage of real-time measurement data, file format: .xls
Clear	Click to clear all the measuring data
Refresh	Click this button to refresh after updating high/ low alarm values

* When the real-time measurement starts, if the product is not connected or the contact is poor, the "Device is not connected" window will pop up. Please reconnect or change to another USB port.

6. Import data

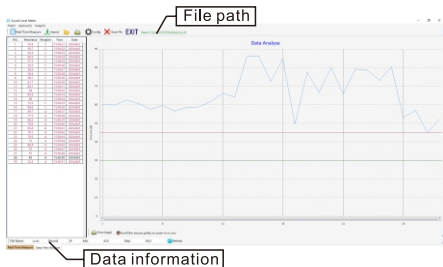

IV. Other

A. Attentions

1. Environment conditions on operation:
 - (1) 2000 meters high below;
 - (2) Temperature: 0~40°C ;
 - (3) Relative humidity: ≤80%RH
2. Do not store or use the unit in following conditions:
 - (1) Splashes of water or high levels of dust.
 - (2) Air with high salt or sulphur content.
 - (3) Air with other gases or chemical materials.
 - (4) High temperature or humidity or direct sunlight.
3. Never impact the unit or used on humidity conditions.

B. Maintenance

1. Maintenance of battery:
 - (1) When you do not use this product for a long time, you need to charge it once a month to avoid affecting the battery life.
 - (2) After startup, when the power supply is insufficient, please charge it in time.
2. Cleaning the casing:

Never use alcohol or thinner to clean the unit casing that will especially erode the LCD surface; just clean the unit lightly as needed with little clean water.



Specific Declarations

- a. We reserve the rights of the update and amendment of the product design and the manual which are subject to change without further notification.
- b. Dispose of battery should in accordance with local laws and regulations.
- c. Our company shall hold no any responsibility resulting from using output from this product as an direct or indirect evidence.

